



- » **Pneumatic Conveying**
- » **Sifting**
- » **Screening**
- » **Milling**
- » **Air Filtration**
- » **Weighing**
- » **Feeding**
- » **Mixing**
- » **Blending**

# Solutions in Bulk Material Handling Systems



Coperion

# Process is Our Purpose

Coperion, a Hillenbrand Operating Company that specializes in engineering cutting-edge technologies and solutions across the bulk material handling spectrum, takes pride in our teams delivering complete solutions for your real-world needs, based on deep process and engineering expertise.

For decades clients around the world have relied on us to deliver the quality, reliability, safety and performance they need through end-to-end process solutions and high-quality precision equipment from well-known and proven brands including Kemutec, Baker Perkins and Raymond Bartlett Snow.

Today, Coperion is more tightly focused than ever: a company focused on food and performance materials, with a distinctive way of doing business. Collaborative. Adaptive. And most of all, committed.

**Coperion delivers custom-designed and engineered solutions for the following applications:**

- » Truck or railcar loading, unloading and bulk storage systems
- » In-plant transfer for major, minor and micro ingredients
- » Minor and micro ingredient scaling systems
- » Low pressure continuous dense and dilute phase handling systems
- » Plant controls systems
- » Dust collection
- » Sifting, storage and mixer transfer systems
- » Ingredient unloading, cleaning and storage systems
- » Liquid storage, scaling and transfer systems
- » Closed loop N2 and CO2 systems
- » Dry ingredient convey systems
- » Trim and reclaim transfer systems
- » Batch and continuous feeding systems



# Project management

At Coperion, everything we do is centered on customer satisfaction. We strive to make your equipment and systems robust and efficient. Our project management teams become an extension of your business with a direct line of communication to the many resources within the Coperion global network. Your Coperion team will take command of the design/build process from the project kick-off all the way to process commissioning. From start to finish, our teams are dedicated to meeting your business goals.

## **Process Controls**

Our Process Controls Group has been entrusted to control processes for some of the world's most recognizable brands. We've been building customized controls for over 40 years and our engineers have an intimate knowledge of industrial processing and production. Our in-depth experience provides field proven solutions.

We can custom design whole-plant or partial systems for new plants or integrate legacy control systems. We make everything from small independent panels to complex multi-processor and distributed I/O control systems. Interface with warehouse management, MES and ERP software systems provide a seamless transfer of data throughout a facility. The Coperion Controls Group forges long term relationships with customers to support large control system implementations, typically utilizing remote access tools allowing rapid resolution of issues or minor operational adjustments.

From analysis and planning, through equipment and control panel design, to testing and long-term service, our customers work with a single point of contact throughout the project.



Commonly Conveyed Products:

- » Flours and Sugars
- » Granular and Pelletized Products
- » Pet Foods
- » Resins and Compounds
- » Specialty Chemicals

# Dilute Phase Conveying

Dilute phase pneumatic conveying systems operate on the principle that the solids will be suspended in the conveying line air stream. This is accomplished by metering product into a moving air stream.

**Types of Dilute Phase:**

- » Dilute Phase Pressure
- » Dilute Phase Vacuum

## Negative Airlift

Coperion Negative Airlift beats belt conveying in seven ways:

- Highest efficiency cyclone
- Lower maintenance requirements
- Lower microbial count
- Better product expansion
- More direct routing from extruder to dryer – resulting in more efficient use of production space
- Partial pre-drying of product during transport to dryer
- Cleaner, drier plant environment

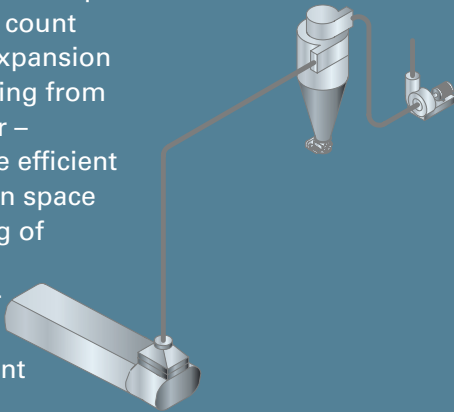

## Enhanced Dilute Phase Conveying (EDIP)

EDIP is a method to enhance the operation of a dilute phase convey system in order to minimize the speed of the blower under all operating conditions. Performance of the operating equipment is translated by EDIP into a tangible conveying velocity set by the user. In addition, the system control responds to the hanging conditions in the convey line to maintain the desired velocity by changing the blower speed. The result is a dilute phase system that dramatically reduces power consumption, material degradation and system wear.

- Minimize velocity in dilute phase conveying
- Reduce energy consumption
- Lower material degradation
- Equipment wear is reduced

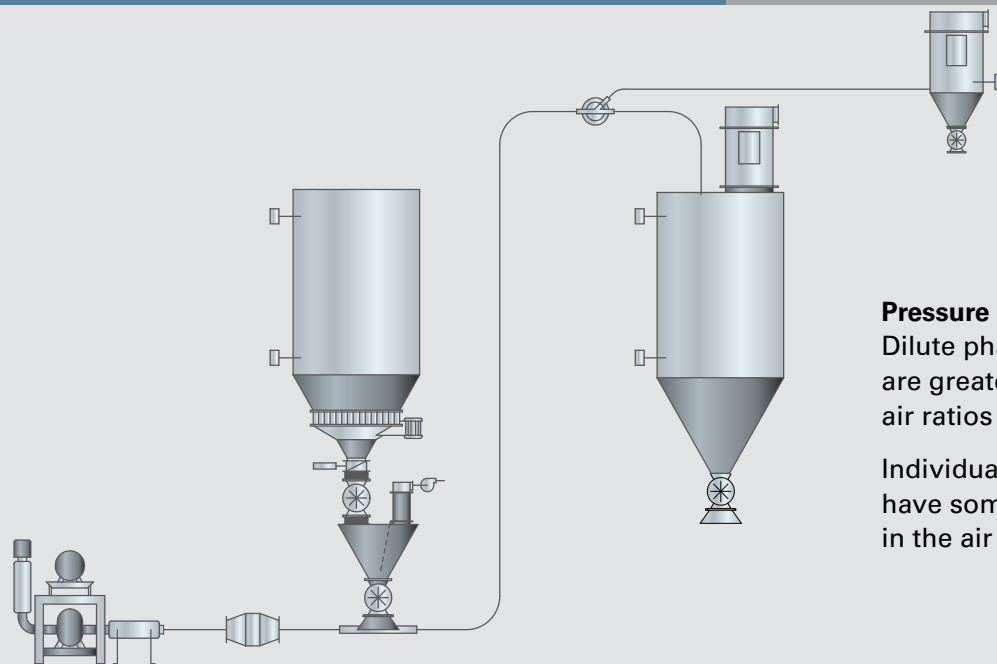
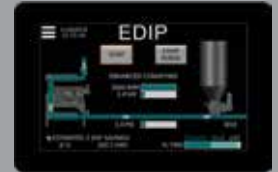

## Pressure Dilute Phase Flow

Dilute phase conveying velocities typically are greater than 3500 FPM and material to air ratios are less than 12 to 1.

Individual particles in the air stream will have some separation by their suspension in the air stream.

## Airlocks and Diverters

Coperion offers a wide range of airlocks and diverter valves for multiple pneumatic conveying applications.

- Easy to disassemble and clean airlocks for sanitary processes like food and pet food
- High throughput airlocks with capacities to handle up to 220,000 lbs. of product per hour
- Diverters are available in 22.5, 30 and 45 degree divert angles for use in diverting air-conveyed or gravity-flow materials into either of two destinations; or from either of two sources to one destination
- Airlocks and diverters are available in stainless steel, cast iron and aluminum



## Blowers

Whether you need pressurized air or to create vacuum pressure, Coperion blower packages will consistently provide you with the proper conditions.

- Both table top and skid mounted packages available
- Line sizes from 2" to 16"
- Blowers for sanitary or industrial applications
- Silencers and enclosures for reducing blower noise
- Full line of replacement valves, filters, motors and gauges

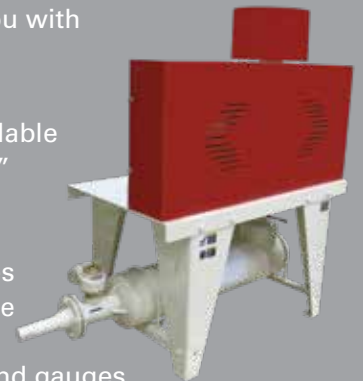

For engineering the ideal pneumatic conveying system Coperion provides table top and skid mounted blower packages for pressurized air or vacuum pressure systems.

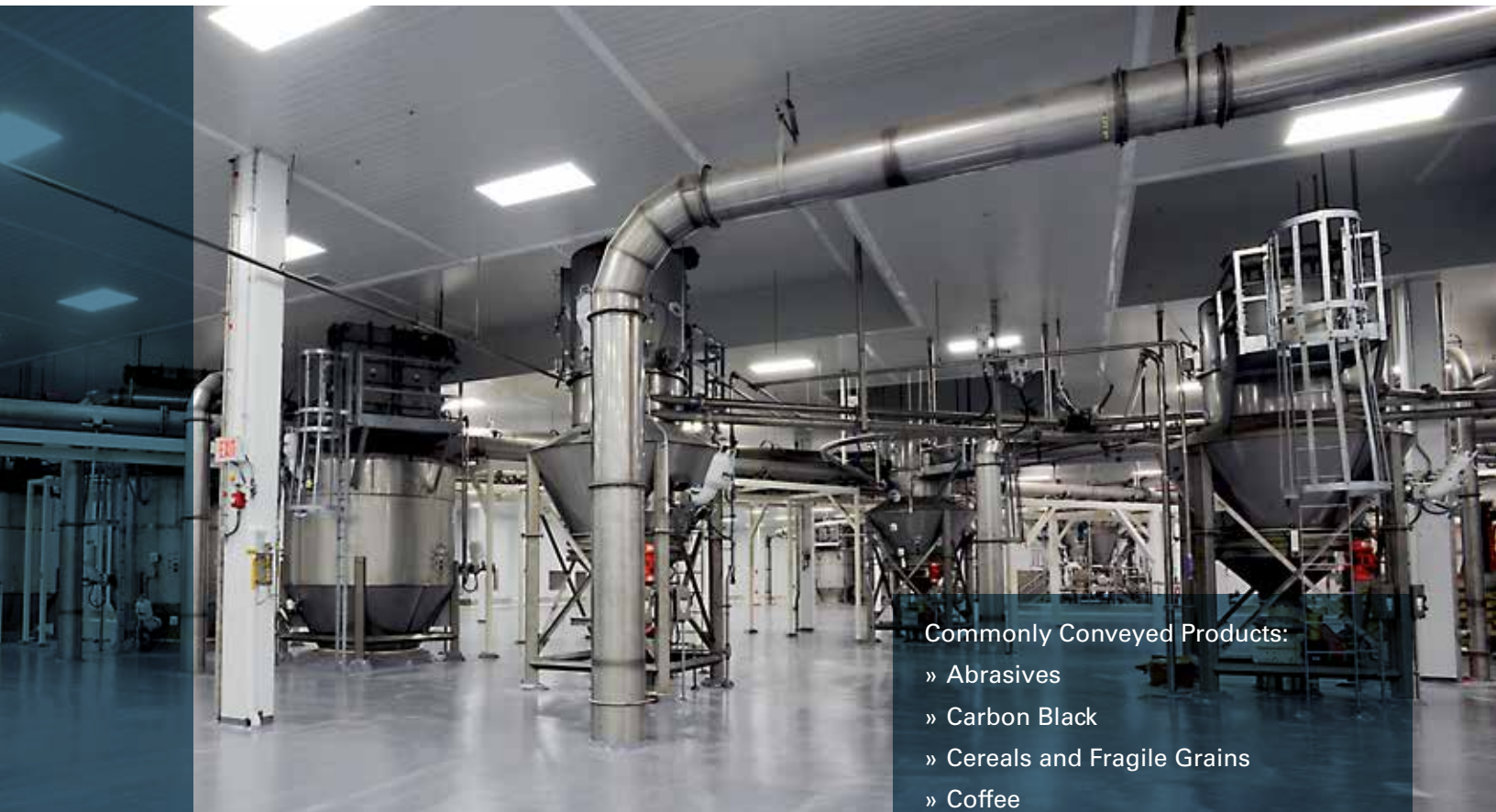

Commonly Conveyed Products:

- » Abrasives
- » Carbon Black
- » Cereals and Fragile Grains
- » Coffee
- » Detergents
- » Fly Ash
- » Nuts
- » Pasta
- » Pet Food
- » Plastic Pellets
- » Sand
- » Sugar

# Dense Phase Conveying

Dense phase pneumatic conveying systems operate at smaller air volumes and higher air pressures. Materials are pulsed through the convey lines and are ideal systems for handling easily damaged or porous products.

**Types of Dense Phase:**

- » Vacuum Dense Phase
- » Batch Dense Phase
- » Continuous Dense Phase (CDP™)
- » Low Pressure Continuous Dense Phase (E-finity®)



**E-finity® – The Most Energy Efficient Continuous Dense Phase Technology Available on the Market**

E-finity® is a low breakage, energy efficient continuous dense phase pneumatic conveying system.

- Improves sanitary conditions and housekeeping
- Produces the lowest degradation available
- Allows for greater system flexibility
- Reduces plant footprint
- Lowest horsepower of any dense phase pneumatic system

The blower air source can be located nearly anywhere in the plant

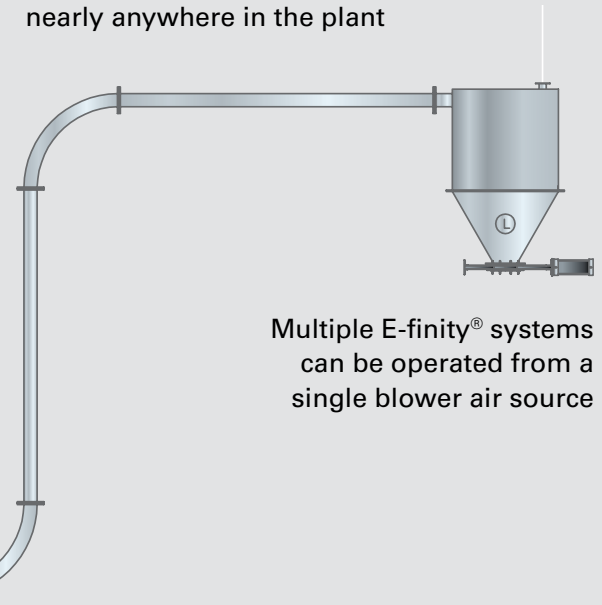

Multiple E-finity® systems can be operated from a single blower air source

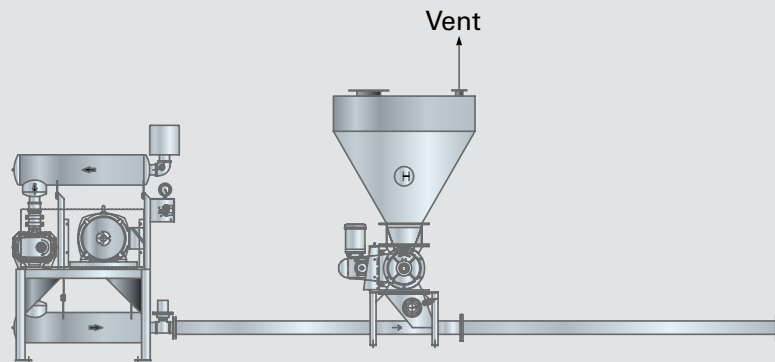

E-finity® Blower

**Coperion Continuous Dense Phase Technology offers the following benefits:**

- Lowest product breakage/degradation
- Ability to operate multiple systems from a single air source
- True continuous feed allows for use with other continuous processing systems
- Reduced control pressure resulting in optimum energy savings
- Simplified air controls for ease of operation
- Comprised of Coperion manufactured components
- Available with either vacuum or pressure modulation option packages for pressurized air or vacuum pressure systems

**Vacuum Dense Phase**

Vacuum Modulating Air Control is the newest generation of vacuum dense phase conveying available on the market.

VMAC uses specially designed modulating air controls that automatically correct feed conditions based on vacuum levels. This insures the system is properly loaded and that the benefits of dense phase are realized.



# High Efficiency Sifting and Screening

## **Sifting:**

- » Policing – removal of extraneous material
- » Scalping – remove small percentage of oversize product
- » De-dusting – removal of fines
- » Deagglomeration – breaking of soft lumps and agglomerates
- » Liquid straining – removal of excess liquid from solid products

## **Screening:**

- » Control screening
- » Multi-deck separation of fines
- » Classification – separation by size
- » De-dusting of dry, powdered and granular products
- » Suitable for high feed rates
- » Handles difficult to screen lightweight products

# Kemutec KEK Centrifugal Sifters

## Industrial Rotary Sifter for Powder and Granule Processing

Features:

- High capacity and high-efficiency sifting
- Gravity and inline pneumatic conveying designs
- Cantilever shaft – no oversized bearing or seal
- 30 second screen changes
- 7 model sizes
- Rates from a few pounds to over 200,000 lbs./hr.
- Easy disassembly for cleaning and maintenance

## In-Line Pneumatic Conveying Applications

Industrial Kemutec KEK Centrifugal (Rotary) Sifters for powder processing, can be used for direct in-line installation into pneumatic conveying lines.

Models available for both:

- Vacuum conveying lines
- Pneumatic conveying lines

Typical operational benefits:

- Direct connection into conveying line
- Compact design
- Can be mounted at floor level
- Easy access for cleaning and maintenance
- No need to disenrain conveying air before sifting takes place



# GKM Screeners

## Tumble Screeners

Suitable for high feed rates and multi-deck separations of fines and lightweight products.

- Screens down to 200 $\mu$
- 1 – 6 screen decks per machine
- Screens are available in stainless steel wire, perforated plate or synthetic fiber mesh
- Model sizes range from 600 - 2,600 mm diameter

## Vibrating Screeners

Designed for high performance on dry, dusty, powdered and granular products.

- Screens down to 200 $\mu$
- 1 – 2 screen decks per machine
- Model sizes range from 450 - 2,000 mm diameter

## Vibrating Control Screeners

A pure control screener that handles dry powdered and granular materials.

- Screens down to 200 $\mu$
- High acceleration; also suitable for solid-liquid separation and wet products
- Screen frames with double clamping ring for fast self-changing
- Model sizes range from 450 - 2,000 mm diameter





Applications:

- » Dry Granulation
- » Wet Granulation
- » Tablet Rework and Re grind

# Kibblers and Cone Mills

## **Kibblers:**

- » Heavy duty lump breaker and pre-breaker
- » Grinds lumps up to 6" down to 1/8"
- » Minimal fines generation
- » Slow-speed, high torque size reduction
- » Quick screen changes
- » Control of milled particle size through screen selection

## **Cone Mills:**

- » High Efficiency – Virtually all the energy input is utilized in the size reduction process.
- » Gentle Grinding Action – Allows uniform size distribution, resulting in minimal fines generation.
- » Low Heat Generation – Essential when milling fatty, sticky or heat sensitive products.
- » Low Dust Levels – No need for air filtration. Keeps installation costs to a minimum.
- » Low Noise – No costly acoustic protection. Mobile units can be used in any location.
- » Flexibility – Freestanding mobile units, standard models as part of process systems and special custom units as an integral part of other equipment and systems.
- » Low Profile Design – Compact design results in low height and low-profile installation.

# Kibbler Applications

## Deagglomeration

Breaking of soft to medium-hard agglomerates in the feed material.

## Pre-Breaking

Pre-grinding of larger lumps of medium-hard material to a milled size that can then be further reduced to a powder in fine grinders.

## Coarse Grinding

Grinding of large lumps of medium-hard materials to less than 1/8" pieces.



# Cone Mill Applications

## Food Industry

- Coarse sugar grinding
- Cookie rework
- Candy and chocolate bar rework
- Dairy powder deagglomeration
- Bread crumbing

## Chemical Industry

- Detergent tablet rework
- Color extension of dye powder in blends
- General deagglomeration processing

## Pharmaceutical Industry

- Dry granulation
- Wet granulation
- Tablet rework and regrind





# Air Filtration Systems

Utilizing over 40 years of Dust Collection Technology Experience

Coperion offers a portfolio of industrial air filtration products that are accepted for a wide variety of dust collection applications throughout the world. As a leader in dust collection technology for over 40 years, Coperion has developed innovative bag and cartridge filtration solutions that ultimately have met a diverse range of customer needs.



**AVR/AVRC Filters (Air Vent Round)**  
Bottom removal (below the tube sheet) filters.

- Without the hopper the filter is ideally suited as a bin vent filter for storage tanks, work bins and surge hoppers
- Filters with a 60° hopper can receive the dust into a bin or through a hopper entry inlet and discharge the collected dust through an airlock for dust disposal
- Can be configured with a pneumatic receiver section and receive product from a vacuum or pressure conveying system
- AVR Filters utilize bag media while the AVRC contains cartridge media



**AVS/AVSC Filters (Air Vent Square)**  
Bottom removal (below the tube sheet) filters.

- Without the hopper the filter is ideally suited as a bin vent filter for storage tanks, work bins and surge hoppers
- With a 60° hopper the filter receives dust through a hopper entry inlet and discharges the collected dust into a bin or through an airlock for dust disposal or recycling
- Can be customized for higher operating static pressures to meet specific application requirements
- AVS Filters utilize bag media while the AVSC contains cartridge media



**AV-2 and AV-4 Filters**  
Compact square or rectangular filter designs.

- Available in either a two bag or four bag arrangement
- Ideally suited for cleaning the air vented from rotary airlocks and surge hoppers
- Suitable for venting small volumes of displaced air



**LVS Filter (Large Vent Square)**  
Bottom removal filters designed to handle medium to high air volumes.

- Particularly suited for applications where headroom is an issue
- Bags can be removed via an access door on the side of the unit



**RPT Filters (Rectangular Pulse Top-Removal)**  
A rectangular top removal bodied filter unit designed to handle high air volumes.

- Bags are removed vertically from the top clean section
- The plenum can be designed as a walk-in plenum so the filter media replacement and maintenance can occur in an enclosure



**RT/RTC Filters (Round Top-Removal)**  
Similar to the AVR Filters, but with top removal. Filter media is installed and removed through the topside, or clean air plenum of the filter.

- Designed for low air volumes, the RT can handle higher pressure or vacuum than a square or rectangular unit
- RT Filters utilize bag media while the RTC contains cartridge media



**ST/STC Filters (Square Top-Removal)**  
Similar to the AVS Filter, but with top removal. The filter media is installed and removed through the clean air plenum of the filter.

- Hinged top doors allow clean air access to the filter media
- ST Filters utilize bag media while the STC contains cartridge media



**High-Efficiency (HE) Cyclone**  
HE Cyclones are designed to separate product from an air stream. The collected product is discharged from the bottom of the cyclone and the clean air is discharged through the top exhaust.

- Operates most efficiently as a pneumatic receiver for the separation of particles up to 20 microns
- Easy to wash down and sanitize, reducing contamination issues



**Ultra High-Efficiency (UHE) Cyclone**  
The Ultra High-Efficiency Cyclone does not have bags, which results in all product being returned to the process.

- Efficiencies up to 99.9%
- A suitable replacement for many baghouses
- Can be configured as a clean-in-place system



### MCF PowerSaver® Dust Collector

As the cost of energy continues to increase, plant managers are continually looking for ways to reduce power consumption. Within our dust collection portfolio is the unique MCF PowerSaver®, a filter that can save up to 50% of operational costs by using medium pressure air for the cleaning cycle. The MCF's integrated blower provides the 0.49 bar medium pressure air for cleaning that eliminates the need for plant compressed air in the filter and frees up existing compressed air capacity for use in other processes.

- Excellent operational capabilities in high dust load applications and in explosive atmospheres.
- Good for operation in temperatures 465 °F (240 °C) and higher.
- Cleaning capacities over 250,000 CFM (425,000 m<sup>3</sup>/h).
- Longer Bag Life – precision cleaning by the MCF PowerSaver® prevents over cleaning and ensures that bag life is uniform and maximized.
- Lower Emissions – medium-pressure pulse complemented by precision cleaning has proven to have much lower emissions than reverse air cleaning filter systems.
- Lower Maintenance Costs – the MCF PowerSaver®'s “no tool design” bag change-out saves hundreds of hours of installation and maintenance over the life of the filter.

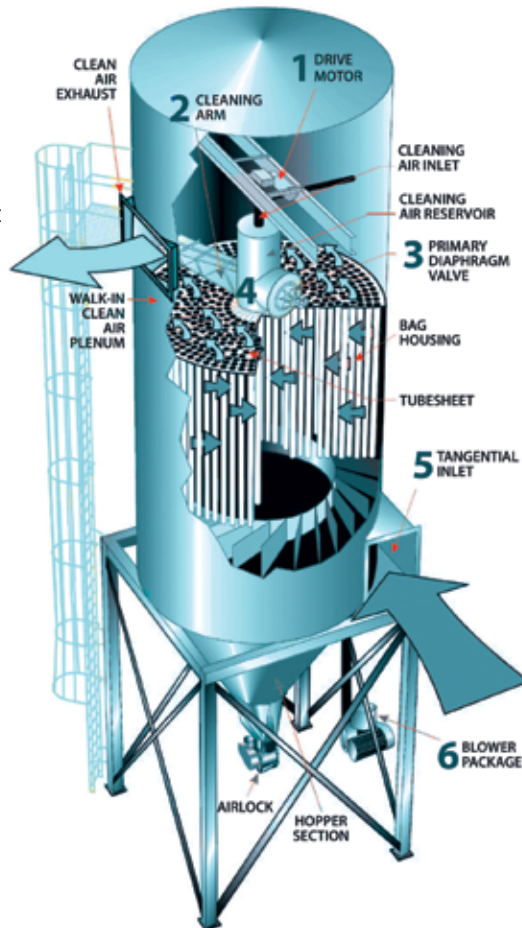
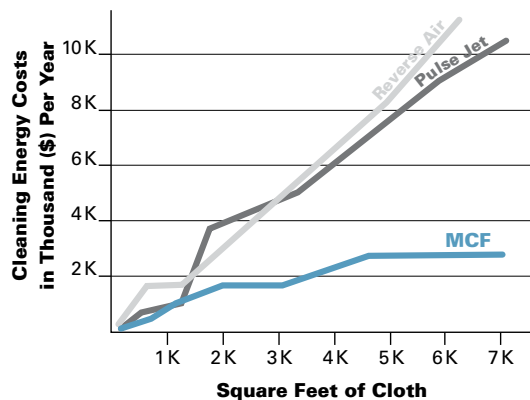

1. Main drive uses rugged electric motor
2. Cleaning arm directs air flow
3. Diaphragm valving assemblies minimize recovery time
4. Index assembly ensures reliable cleaning
5. Tangential Inlet controls heavy dust loads – optional high-entry inlet controls light dusts
6. Medium-pressure blower package saves energy



### Vertical Cartridge Filter (VCF)

The Vertical Cartridge Filter (VCF) removes industrial dusts while incorporating a unique design for handling medium to high air volumes.

- Front access cartridge replacement speeds change out of filter media
- Cartridge clamp system assist-levers disengage filters from tubesheet for simple service
- Unique cartridge design promotes better cleaning when pulsed, which prolongs service life
- Robust design for enhanced explosion protection lowers overall cost
- Easy maintenance with no confined space entry requirement



### Central Vacuum System

High-performance central vacuum capability.

- Multi-user or single-user application
- Self-cleaning separator
- Broad range of tools and accessories

### Air Filtration On-Site Surveys

Coperion offers a wide range of engineering services that facilitate the optimum air filtration design, installation and operational efficiency. Our On-Site Surveys are a key component to assuring your dust collection system is operating at peak performance. The program includes the following key components:

- On-site dust collection analysis
- Particle size analysis and emission testing
- Field measurement of dust producing equipment and plant layout
- Preliminary sketches of plant/equipment layout as it exists today
- Preliminary drawings of the plant/equipment layout to include appropriate NFPA recommendations
- Pictures, data, details and all pertinent information required to evaluate current condition of dust systems
- Evaluate physical conditions of existing filters, fans and airlocks
- Evaluate existing ductwork layout and sizing, duct discharge design, and pneumatic transfer system
- Consult with customer personnel to determine system rates, equipment functionality, problem areas, and desired results from findings
- Provide quotation for new and upgraded solutions





**Feeding Capabilities:**

- » Volumetric
- » Gravimetric
- » Screw or Vibratory
- » Flex Wall or Internal Agitation

# Precise Feeding Systems

Applying over 40 years of Coperion Feeding Technology

**Commonly Fed Materials:**

- |                     |                          |                          |
|---------------------|--------------------------|--------------------------|
| » Avicel            | » Iron Oxide             | » Salt                   |
| » Calcium Carbonate | » Lime                   | » Sugar                  |
| » Carbon Black      | » Peanuts                | » Talc                   |
| » Cereal            | » Pharmaceutical Powders | » TiO <sub>2</sub>       |
| » Detergent         | » Plastic Pellets        | » Wet Chopped Fiberglass |
| » Flour             | » Polymers               | » Wood Flour             |
| » Fumed Silica      | » PVC Resin              | » And Many Others        |



### MechaTron® Low Range Coni-Flex Feeder (LC) & Coni-Steel Feeder (LS)

Designed with either a Coni-Steel (stainless steel) feed hopper or Coni-Flex (flexible hopper), the MechaTron® Low Range Feeders are perfect for handling minor ingredients at low feed rates.

- Easy disassembly simplifies cleaning and maintenance
- Feed rates from .002 to 21 cubic feet (.057 to 595 liters) per hour



### MechaTron® Mid Range Coni-Flex Feeder (MC) & Coni-Steel Feeder (MS)

Designed with either a Coni-Steel (stainless steel) feed hopper or Coni-Flex (flexible hopper), the MechaTron® Mid Range Feeders handle feed rates up to 330 cubic feet (9,300 liters) per hour.

- Disassembly from the non-process side of the feeder speeds maintenance
- Volumetric and gravimetric configurations



### MechaTron® High Range Coni-Flex Volumetric Feeder (HC) & Coni-Flex Gravimetric Feeder (HC)

The largest of the MechaTron® Feeder line, the high range models handle feed rates up to 1,100 cubic feet (31,150 liters) per hour.

- Flexible internal hopper that is easily removed for cleaning and maintenance
- Operates both volumetrically and gravimetrically



### MechaTron® Mid-Range Coni-Flex 3-A Feeder (MC)

A 3-A accepted feeder for food, dairy and other sanitary applications.

- Crack and crevice-free contact surfaces are ground and polished to 32 micro-inches RA
- Feed rates up to 330 cubic feet (9,300 liters) per hour



### MechaTron® Low-Range Coni-Steel Vibratory Feeder (LS)

MechaTron® Vibratory Feeders are uniquely designed with a maintenance free feed chute for gently feeding materials such as powders, granules, chips, flakes and fibers.

- Gravimetric accuracies from  $\pm 1/4\%$  to 1% and volumetric accuracies from  $\pm 2$  to 5% of feed rate setpoint at 2 sigma
- Feed rates up to 353 cubic feet (10,000 liters) per hour



### SolidsFlow™ 2000 Feeders

SolidsFlow™ 2000 Vibratory Feeders have sanitary USDA accepted and industrial models that provide feeding solutions for a number of industries ranging from dairy to plastics.

- No moving parts reduce maintenance and parts replacement
- Natural mass flow feeding device that eliminates material segregation



### SolidsFlow™ 7000 Fibrous Feeder

The SolidsFlow™ 7000 feeder was designed to solve the flow problems typically associated with feeding fibrous materials.

- A natural mass flow feeding device that handles difficult to feed materials
- Excellent for feeding wet chopped fiberglass



### MechaTron® AI & AP Feeders

Designed in both sanitary and industrial models, the MechaTron® AI and AP feeders meet the application needs for a number of industries such as pharmaceutical, nutraceutical, food, plastics and chemicals.

- Quick and easy disassembly for cleaning and maintenance
- Feed rates from 0.5 Kg to 150 Kg per hour



### AccuRate® Series Feeders

The original AccuRate® Feeder that continues to serve customers around the world in volumetric feeding applications.

- Feeding accuracies of  $\pm 0.5\%$  to 3%
- Four different models provide feed rates that span from .0000017 to 280 cubic feet per hour



**Weighing Capabilities:**

- » Volumetric
- » Gravimetric
- » Sanitary
- » Batching
- » Totalization

# Weighing

Accurate systems in bulk material handling

**Applications:**

- » Handling fragile (friable) materials such as popcorn or fibers
- » Wide range of feed rates
- » Where headroom is limited
- » Abrasive materials
- » Free-flowing materials
- » Throughput measurement
- » Flow rate monitoring



### DEA 300 Weighbelt

Weighbelt feeder that can be used for weight controlled feeding, as a weight indicator and totalizer, or for batching.

- Perfect for weighing and feeding easily damaged materials
- Ideal for low headroom applications
- Feed rates up to 660 cubic feet (18,961 liters) per hour



### DEA 600 Weighbelt

Designed as a high capacity industrial weighbelt feeder for feeding easily damaged, abrasive and free flowing materials.

- Accuracies from  $\pm 0.25\%$  to 1% of set rate at 2 sigma
- Easy belt removal for maintenance
- Feed rates up to 1,680 cubic feet (47,578 liters) per hour



### DMO Weighfeeder

A weighfeeder robustly designed for challenging environmental conditions.

- Direct multiple cell weighing system without levers or counterbalance weights
- Handles materials up to 4" (102 mm) in particle size
- Feed rates up to 500 tons per hour



### DEA Open Frame Weighbelt

An open frame weighbelt feeder designed specifically for sanitary process applications.

- Tool-less removal of both the belt and sanitary flex connector for quick cleaning and maintenance
- Open frame design simplifies equipment washdown
- Direct drive system on the tail pulley eliminates potential product contamination



### Load Cells

Compactly mounted, the weighing system is ideal for weight measurement on hoppers, silos, containers and others.

- Simple, rugged design providing highly accurate measurements
- Maintenance free
- Resistant to environmental forces

# Mixers and Blenders

For the mixing and blending of powders and granules under the Gardner brand name Coperion offers double cone blenders, vertical mixers, ribbon mixers and plow mixers. Each is designed to handle a wide range of materials.

## Gardner Ribbon Mixers

A horizontal mixer for the consistent batch and continuous blending of powders and granules.

- Available with cantilever shaft up to 53 cu. ft. (1,500 liters)
- Liquid spray addition options
- Size range from 1.25 to 1,760 cu. ft. (35 – 50,000 liters)



## Gardner Plow Mixers

A high energy, high shear, high-speed plow mixer with cylindrical short aspect ratio mixing chambers that cut mix times to a few seconds.

- High intensity mixing action
- Side cutters for extra shear energy
- Size range from 1.75 to 880 cu. ft. (50 – 25,000 liters)



## Gardner Double Cone Blenders

Blends free-flowing powders and granules while incorporating a gentle tumbling action for handling delicate and fragile materials.

- Hygienic design with no internal seals
- Minimal attrition when blending abrasive materials
- Size range from 1.5 to 3,500 cu. ft. (40 to 100,000 liters)



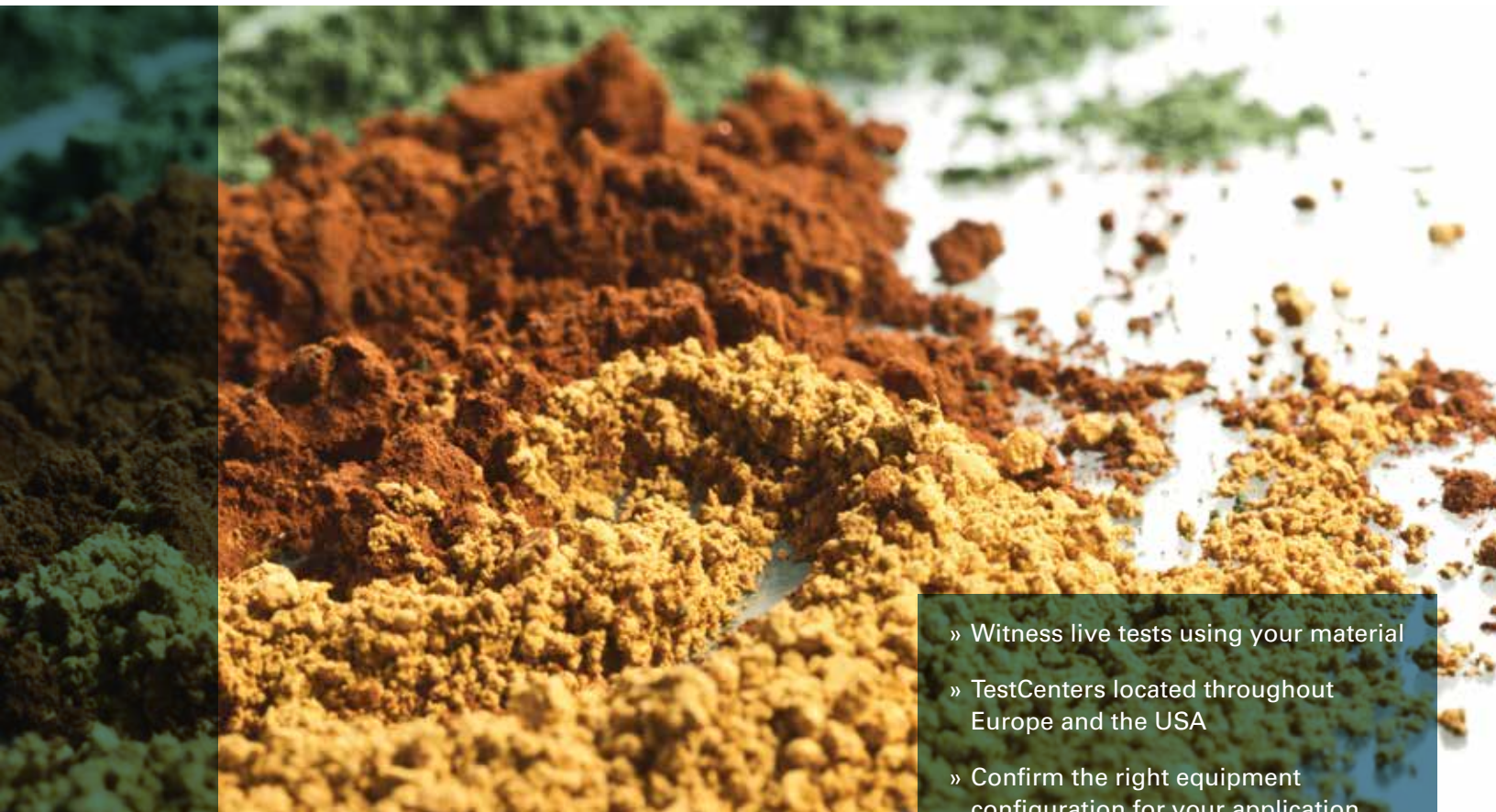

- » Witness live tests using your material
- » TestCenters located throughout Europe and the USA
- » Confirm the right equipment configuration for your application
- » Testing for weighing, feeding, pneumatic conveying, mixing, blending, milling, screening and air filtration

# If you were a bulk material, we'd know everything about you

If you were our customer, we'd have already tested your product. No matter what materials you work with, we know about them and have tested the appropriate feeder, blender, or pneumatic conveying system for them. That's because we've already tested more than 4,000 bulk materials in more than 40,000 tests – delivering results you can rely on.

If your particular product hasn't been tested yet, our TestCenter will soon provide you with comprehensive answers. Proven bulk materials technology from Coperion. Tested and approved. So you can be certain that our feeders, blenders and pneumatic conveying systems are perfectly compatible with your materials.



# Complete after-sales solutions for your requirements

Looking for after-sales solutions? Our extensive AfterMarket program provides you with after-sales services – customized to your specific requirements.

The framework of our AfterMarket program is designed with you in mind. With the guidance of our experienced after-sales team, you can create AfterMarket packages comprised of original spare and wear parts, various services and high-quality components to meet your needs.

Our AfterMarket program is based on a modular principle – you can pick and choose any individual product or a combination thereof. AfterMarket service categories focused on repair, inspection, management and support help to easily find the appropriate products.

We welcome the opportunity to provide you with individual consultation, either as part of an AfterMarket contract or on an individual basis. Whatever Full Service means to you – let's create it together!

# Aftermarket Spare Parts, Service and Maintenance



## Airlocks

A full line of high and low pressured designs with round or square flanged openings are available.

- Operating pressures up to 60 psi
- Can handle temperatures up to 450 °F (232 °C)
- Ruggedly built in cast iron, anodized aluminum or stainless steel
- Easy to disassemble models available for quick cleaning and inspection



## Valves

Valves for gravity flow control and shut-off for dry bulk material handling.

- Iris valves for bins, hoppers, bulk bags and pass-thru ports
- Butterfly valves for powders and granules in sanitary applications
- Knife gate and orifice-type slide gate valves for dry products



## Dust Collectors

Parts supplied for bin vents and filter and vacuum receivers.

- Filter cartridges with MERV 15 high efficiency ratings
- Parts to help meet the EPA's national air quality standards and NFPA guidelines
- Available parts include filter bags, cages, polioleets, cartridges, venturis, clamps, gaskets and explosion panels



## Conveying Line Components

A full line of components to meet pneumatic conveying needs.

- Couplings: Cam and groove, no-ledge, compression, quick-on, and a variety of specialties
- Convey Elbows: Long and short radius available in aluminum, stainless steel, ceramic, abrasion resistant, carbon or galvanized
- Hose: Standard and food grade, rubber, anti-static plastic, stainless steel or galvanized



## Services

Handling baghouse maintenance, equipment repair and rebuilds, installations and start-ups.

- Replace or upgrade filter bags, cartridges or cages
- Rebuild rotary airlocks, valves and coal feeding systems
- Equipment start-up and calibration



## Diverter Valves

Product and clean air diverters are available in 22.5, 30 and 45 degree divert angles for use in diverting conveyed air or gravity-flow products.

- Available in line sizes from 2" to 12" with larger dimensions offered for gravity flow products
- Constructed in carbon steel, stainless steel, aluminum or cast iron
- Scale valves, plug style diverters, flapper style diverters, air diverters and gravity flow diverters are available



## Helixes

A wide variety of helixes for dry material screw feeding processes.

- Helixes for cohesive/adhesive, friable and floodable materials
- Spreading applications
- Designed in 304, 316 and 316L stainless steel and can include various coatings



## Nozzles

Customized nozzles for volumetric and gravimetric screw feeders.

- Nozzles with cross wires for minimizing material pulsations
- For spreading, batching and sanitary feeding applications
- Handles floodable, abrasive, friable and cohesive materials



## Blower Packages

Supplying engineered packages and replacement parts.

- Valves: Pressure relief valves and check valves
- Silencers & Enclosures: Reduce blower package noise
- Filters: Inline air filters for 99% plus removal efficiency
- Gauges: Pressure and vacuum gauges
- Blowers and motors for all industries

BV-P5069GB All information is given without obligation.  
All specifications are subject to change. © 2025



Coperion provides the widest selection of bulk material handling equipment and systems in the industry. We are committed to providing excellent products and services for our customers throughout the world.

# Expertise in process equipment and systems



**Coperion**  
7901 NW 107th Terrace  
Kansas City, MO 64153  
816-891-9300  
info@coperion.com  
www.coperion.com/fpm