



## Bulk Bag Discharger with Dual Screw Transfer and Dual Container Fill Station

### Application Details:

NBE CSO: E602160003

Material: Aluminum Oxide

Bulk Density: 15 to 25 lbs/ft<sup>3</sup>

Particle Size: Powder

Flowability: Can flow like "water"

Area Classification: General Purpose

Discharge Rate: 9+ lbs/20 seconds

Accuracy: Maximize volume in the container

### Application Overview:

NBE was asked to evaluate an existing bulk bag discharger that a customer had repurposed and was experiencing rate and severe "house cleaning" issues. The existing bulk bag discharger was not designed to handle the challenging characteristics of aluminum oxide. The main issues are picking up and transferring the material as well as lacking any type of dust containment. The discharge of the screw conveyor included a cardboard fabricated dust collection hood over a container fill station. After our on-site evaluation, we completed material testing at our Innovation Center to further analyze the aluminum oxide handling issues and completed material transfer (rate) and densification testing. NBE was asked to provide dust collection, increase throughput and maximize the material volume in each container. To increase the rate, we supplied an agitator hopper, dual discharge screw conveyors feeding two separate fill stations that included independent scales. A central dust collection system located on the bulk bag discharger was provided to control and reclaim any captured dust. The NBE system is filling 33% more material per container and double the throughput.

LET	REVISION NOTES	REVISIONS	NAME	DATE
A	ISSUED FOR APPROVAL		MGL	03/12/21
B	REVISED AND RE-ISSUED FOR APPROVAL		MGL	05/11/21
C	CONTROL PANELS CHANGED AND PNEUMATIC CHANGED		MGL	07/28/21

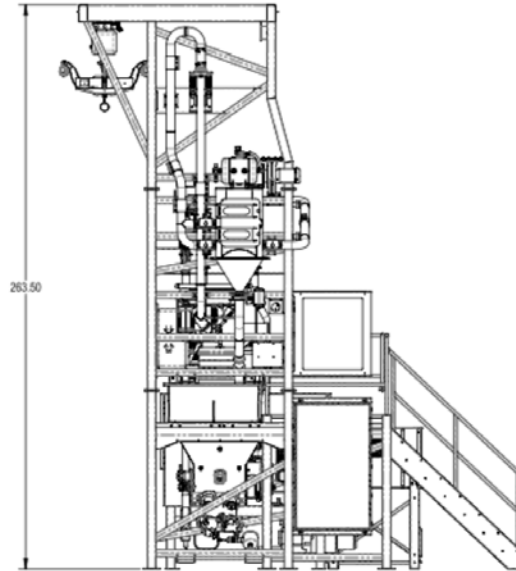
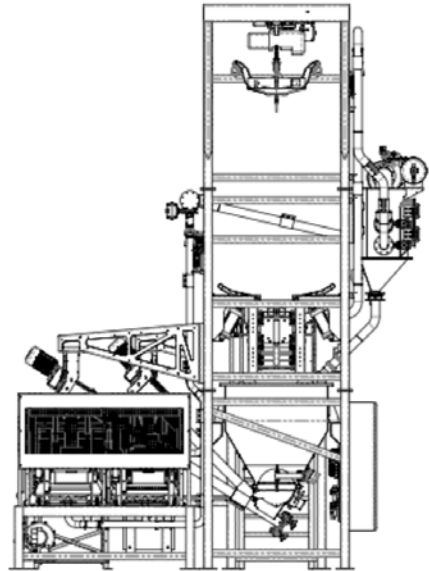
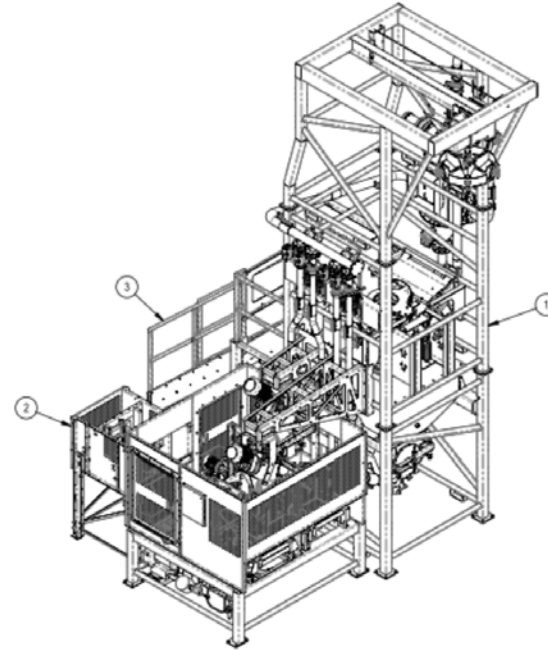
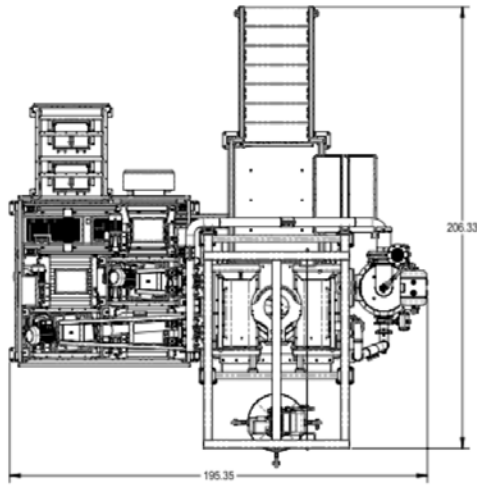

ELECTRICAL SCHEMATIC: 04826500  
 PNEUMATIC SCHEMATIC: 04229800

A319000-01H ASSEMBLY BULK BAG DISCHARGER/SAGGER FILLER 304SS/CS

ITEM	QTY	PART NO.	DESCRIPTION
1	1	A319901-01H	ASSEMBLY BULK BAG DISCHARGER 304SS/CS
2	1	A319031-01H	ASSEMBLY FILL CONVEYORS 304SS/CS
3	1	A319100-01C	ASSEMBLY PLATFORM

APPROVED: PROCEED AS DRAWN	<small>THIS DOCUMENT CONTAINS PROPRIETARY INFORMATION AND IS THE PROPERTY OF NATIONAL BULK EQUIPMENT INC. THIS INFORMATION IS NOT TO BE REPRODUCED OR TRANSMITTED IN ANY FORM OR BY ANY MEANS, ELECTRONIC OR MECHANICAL, INCLUDING PHOTOCOPYING, RECORDING, OR BY ANY INFORMATION STORAGE AND RETRIEVAL SYSTEM. NATIONAL BULK EQUIPMENT INC. ACCEPTS NO LIABILITY FOR ANY DAMAGE TO PERSONS OR PROPERTY ARISING FROM THE USE OF THIS DOCUMENT.</small>
APPROVED WITH REVISIONS NOTED	
NOT APPROVED: REVISE AND RESUBMIT	
<b>National Bulk Equipment</b> <small>1808 STAINLESS DR. HOLLAND, MICHIGAN 48064</small> <small>PHONE: (810) 390-2280 www.nbe-eq.com</small>	
<small>MODEL CREATOR MGL 02/29/21 DWD BY MGL DATE 03/11/21</small> <b>BULK BAG DISCHARGER / SAGGER FILLER</b> <small>NOTE: SEE ALL DIMENSIONS IN "REVISED" TYPED DIMENSIONS SUPERSEDE THE ORIGINAL DIMENSIONS</small>	
<small>1:26 15 OF 15 D</small> <b>A319000 C</b>	



## Existing Equipment Configuration



## NBE Bulk Bag Discharger & Fill Station Configuration

