



## Bulk Bag Discharger

### Application / Equipment Details:

- NBE CSO: E402340027
- Material: RCC (reactive calcium carbonate, fly ash alternative)
- Bulk Density: 31.4-56.2 PCF
- Particle Size: Fine
- Rate: 616 cubic feet per hour

**Application Overview:** The customer was looking for a bulk bag discharger with a rigid screw conveyor to mount on a customer-supplied flat bed truck to discharge RCC material onto their client's mixer. The bulk bag discharger is equipped with a portable base with fork pockets for ease of movement, with bolt together frame section to allow the unit to be disassembled for transport. The upper framework includes additional fork pockets and lifting eyes on the rigid screw conveyor for ease of raising and lowering. The framework assembly was also equipped with an air compressor to provide compressed air to massage paddles, air-purged shaft seals, etc. The assembly also included a dog house cover to protect the equipment from weather elements. The bulk bag discharger was equipped with load cells to shut off the rigid screw conveyor after the desired weight was discharged.

# Real Results APPLICATION OVERVIEW

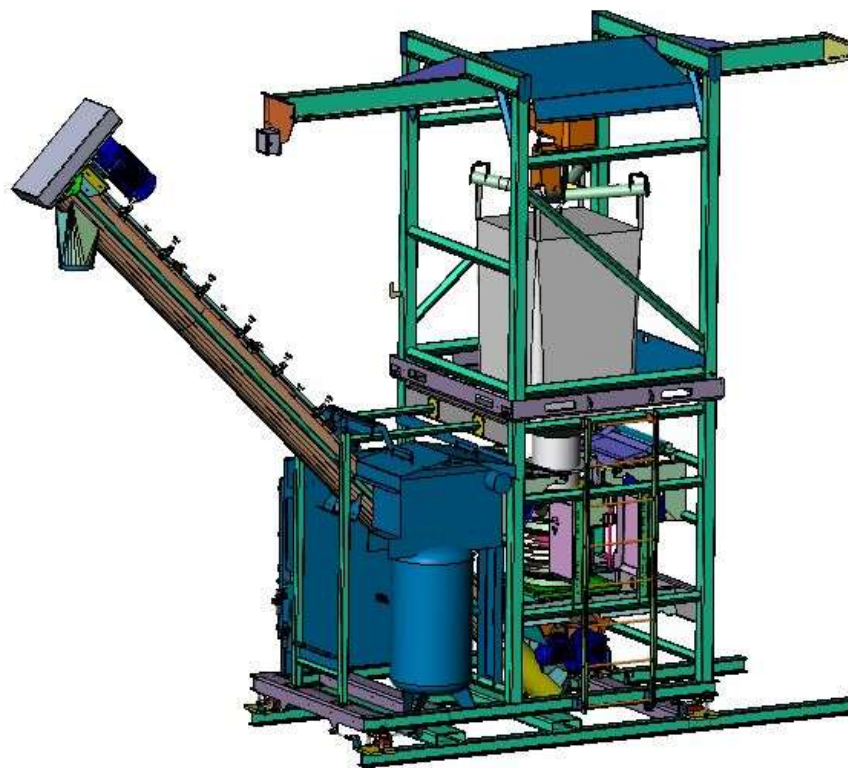

# Real Results APPLICATION OVERVIEW

