

## Portable Single Drum Fill Station

### Application Details: E602060058

Material: Zinc Stearate & Calcium Carbonate

Bulk Density: 23-37lbs/ft<sup>3</sup>

Particle Size: 50-300 Micron

Flowability: Free-Flowing

Area Classification: Class II Division 2 Group F

Customer Requested Rate: 8 Drums/hour

Clean Procedure: Dry Wipe

### Application Overview:

Portable single drum fill station designed to integrate with the current bulk bag filler. An operator will manually position the drum filler under the existing Bulk Bag Filler. The equipment includes independent pneumatic knife gate, drum filler controls with a load cell scale package. The controls will open and close an existing feed valve.



SolidWorks 3D equipment model



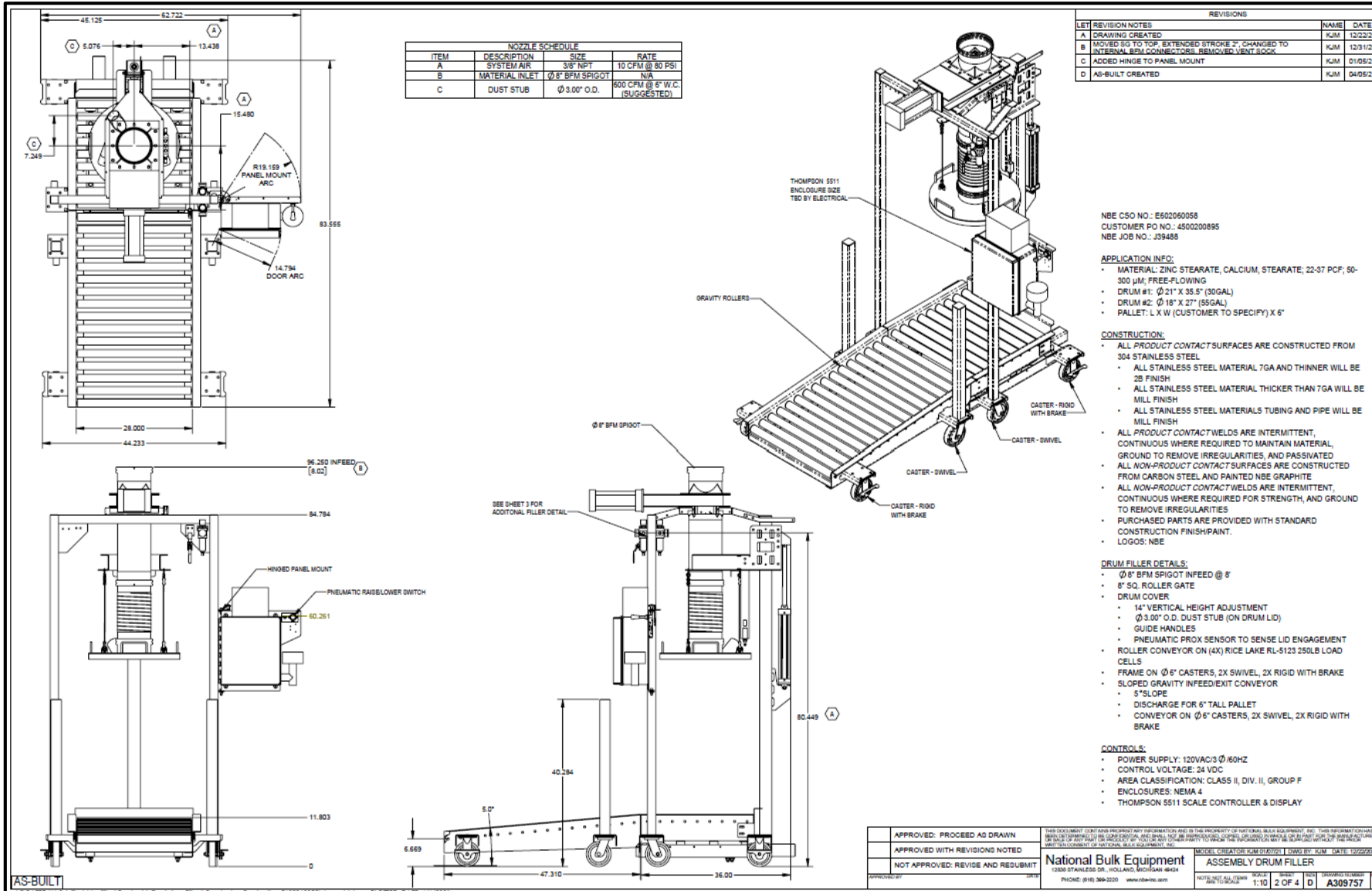

Existing Bag Fill Station. The Portable Drum Filler is manually position & connected to the Bag Filler.