

## Automated Bag Opening & Batch Mixer Ingredient Preparation System

### Application Details:

NBE CSO: E342034048

Material: Various Bakery Ingredients

Bulk Density: Varies

Type of Package: Kraft Paper Bag

Area Classification: Class II Division 2 Group G

Clean Procedure: Dry Wipe

### Application Overview:

Customer that manufactures bakery mixes needed a high speed batching system for their mixers. Most of their ingredients for their batches are supplied in 50 lb. bags. They wanted to streamline the bag opening process for their blends and be able to store batches in bulk bags so that these would be available to discharge into the mixers when needed. This would avoid having the bag opening process being the bottleneck to their production of bakery mixes. National Bulk Equipment supplied a high speed sanitary bag opening system operating at a rate of 12 bags/minute to meet the production needs of the customer. Bags were conveyed to the bag opening system by a series of conveyors and a bag elevator. The bag opening system automatically opened and separated out the ingredients from the bags. A series of screens were integrated within the bag opening process to achieve product quality. A bulk bag filling system was provided underneath the discharge of the bag opener. Ingredients discharged into a bulk bag and the empty bags were sent to a compaction unit. These fully batched bulk bags could now be stored and used as needed in their process.



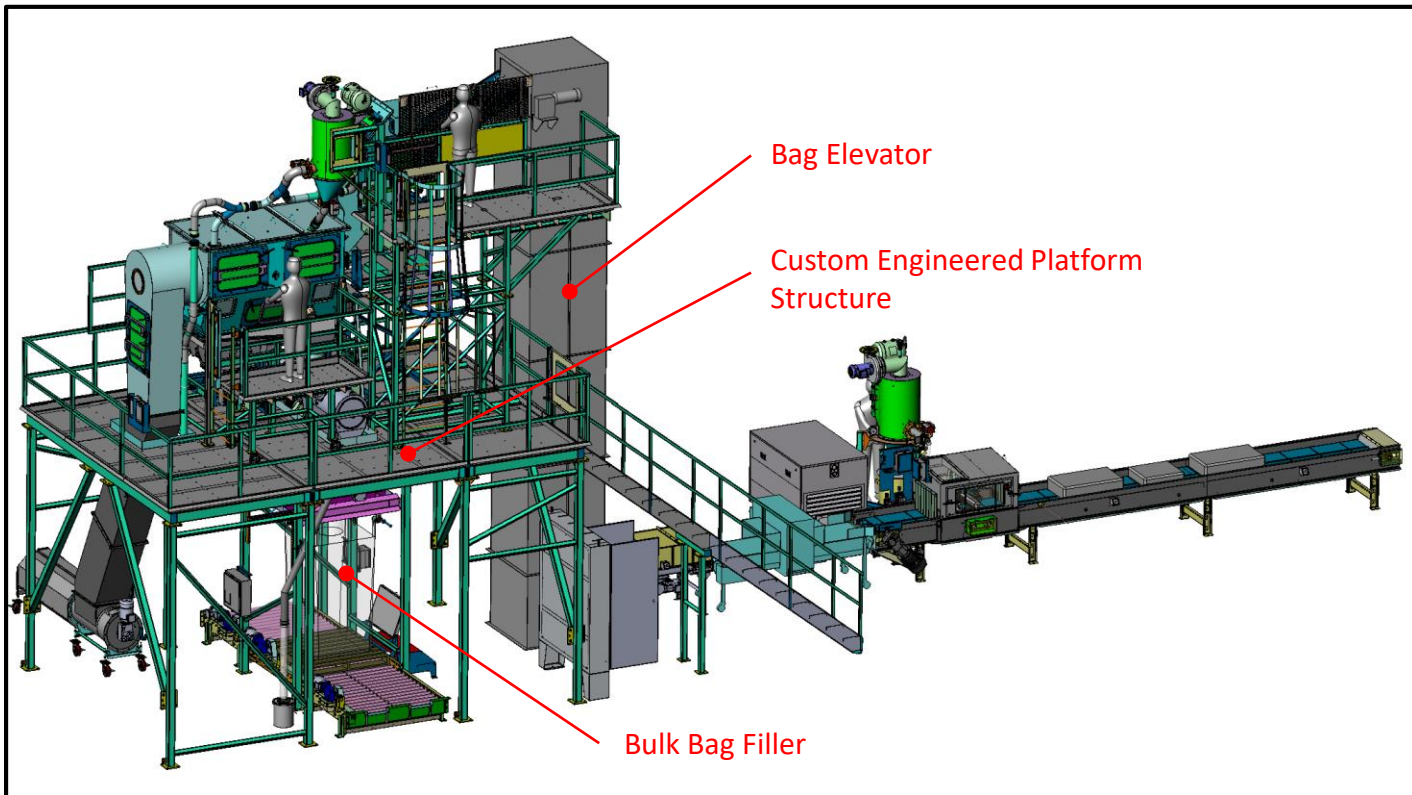
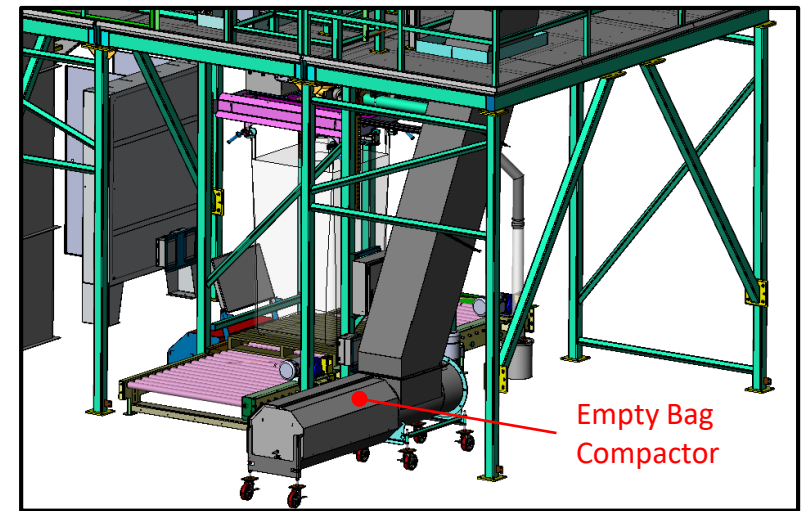
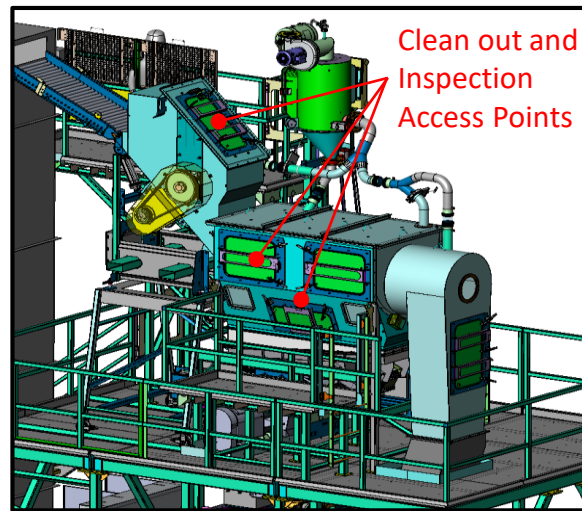
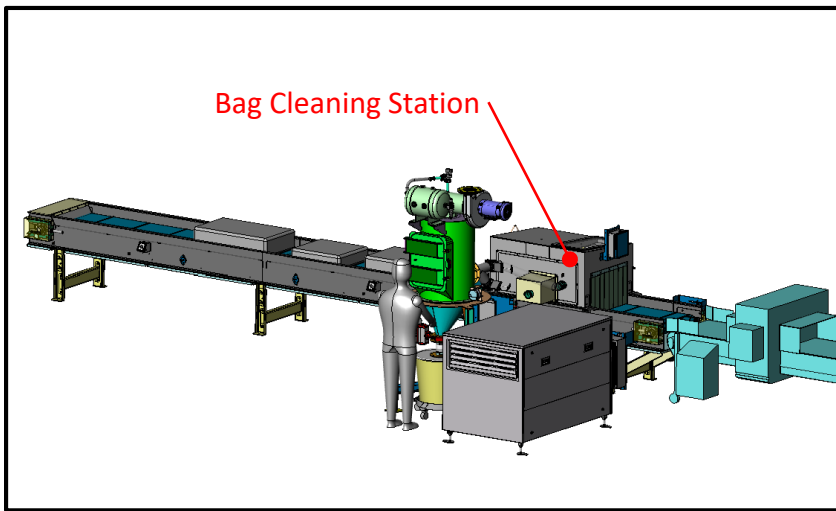

## Bag Cleaning Station

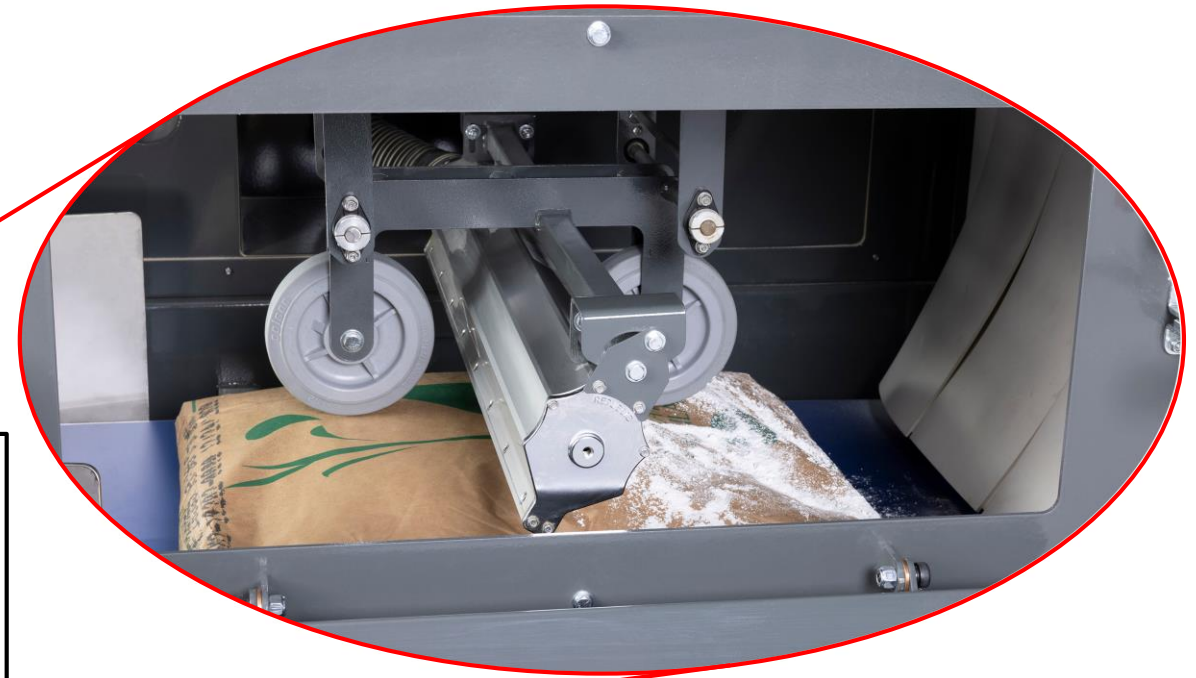
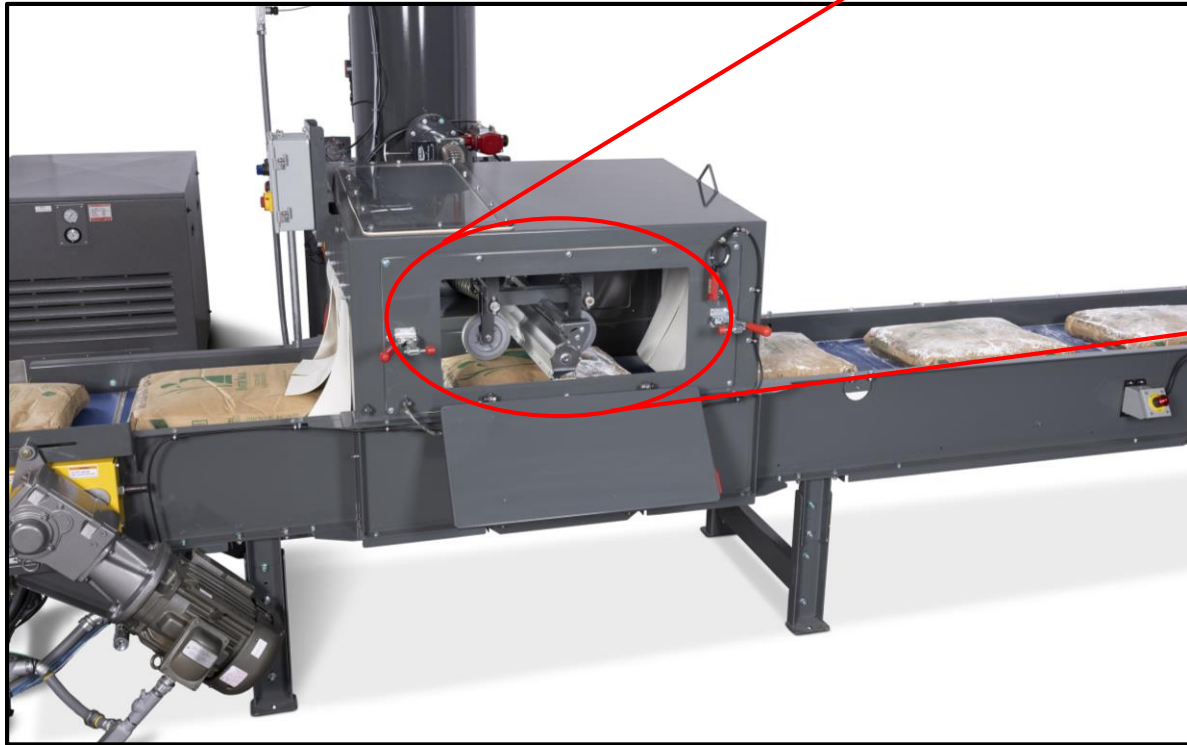

REVISIONS		NAME	DATE
LET	REVISION NOTES	TJB	12/14/2020
A	ISSUED FOR APPROVAL		

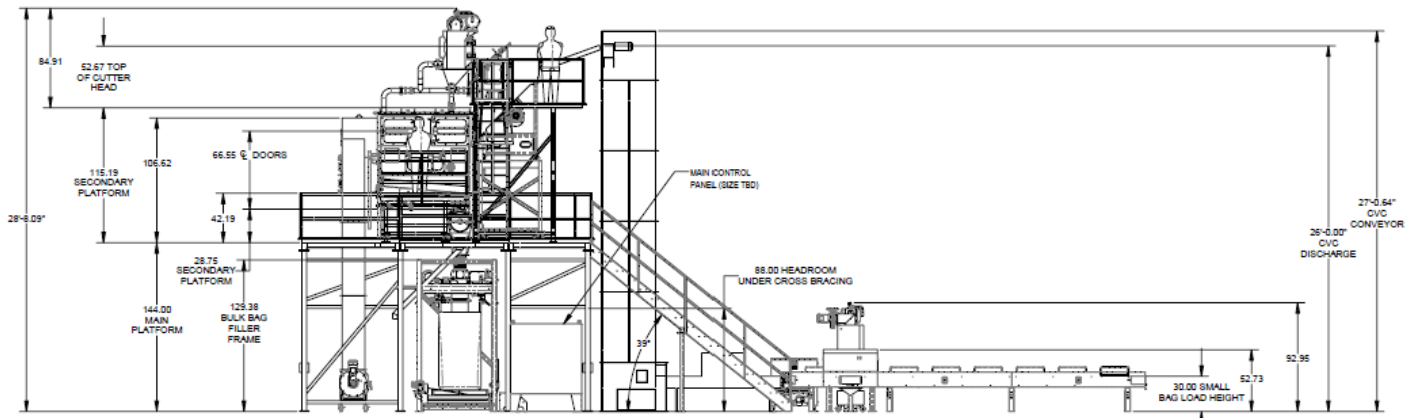

VIEW LOOKING EAST

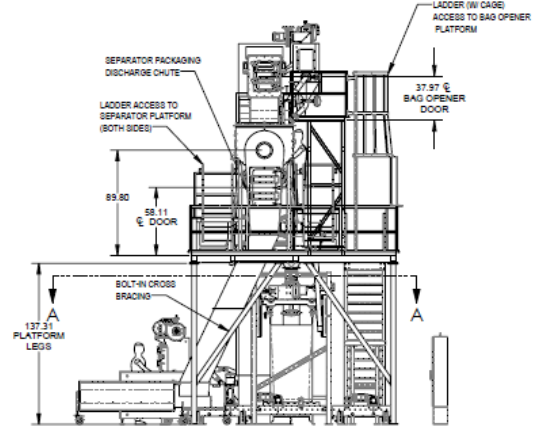

VIEW LOOKING SOUTH

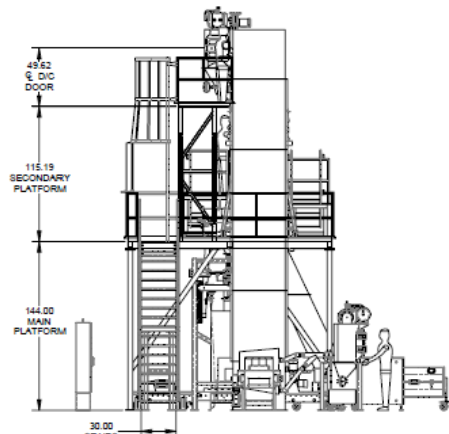

VIEW LOOKING NORTH

PURCHASE ORDER NO: 251839  
 NBE CSO #: E342034048  
 NBE JOB #'s:  
 • BAG OPENER J39131  
 • CONVEYOR J39132  
 • SIFTER J39133  
 • COMPACTOR J39134  
 • PLATFORM J39135  
 • CONTROLS J39136  
 • DUST COLLECTOR J39137  
 • BULK BAG FILLER J39138

GENERAL ARRANGEMENT - ELEVATION VIEWS

APPROVED: PROCEED AS DRAWN	THIS EQUIPMENT CONTAINS HIGH-VOLTAGE INFORMATION AND IS THE PROPERTY OF NATIONAL BULK EQUIPMENT, INC. THIS INFORMATION SHOULD BE KEPT CONFIDENTIAL AND SHALL NOT BE DISCLOSED, COPIED, REPRODUCED, OR IN ANY MANNER MADE AVAILABLE TO ANY OTHER PARTY WITHOUT THE WRITTEN PERMISSION OF NATIONAL BULK EQUIPMENT, INC. MODEL CREATOR: THIS DOCUMENT DRAWN BY: TJB DATE: 12/14/2020 NATIONAL BULK EQUIPMENT 12855 STAINLESS DR., HOLLAND, MICHIGAN 49424 PHONE: (616) 369-2220 www.nbe-inc.com NOT SCALE DRAWING SCALE: 1:48 SHEET: 3 OF 5 DRAWING NUMBER: A313554 A
APPROVED WITH REVISIONS NOTED	
NOT APPROVED: REVISE AND RESUBMIT	

