

The X37 Series

SAFELINE

X-ray Inspection



X37 Series

X3710 X-ray System

X3720 X-ray System

X3725 X-ray System

X3730 X-ray System

X3735 X-ray System

X3750 X-ray System



X37 Series of X-ray Systems Inspection of Tall, Rigid Containers

X37 Series

The Big Difference is in Every Detail

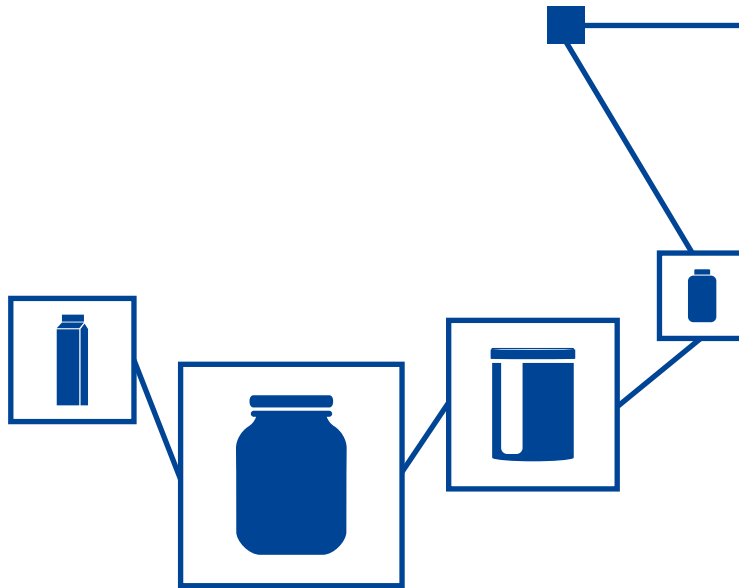

The X37 Series offers the most technically advanced x-ray inspection system on the market for tall, rigid containers. It provides a competitive advantage to food and pharmaceutical manufacturers, by providing a highly adaptable solution to suit individual applications, by offering a wide range of features, combined with low-power consumption, making the X37 a future-proof investment.

An improved user experience and a highly-functional design makes the X37 Series truly market-facing and encapsulates the most advanced development in inspection capability, reducing the Total Cost of Ownership (TCO) and providing customers with the tools to achieve compliance with industry standards.

With a choice of detectors and generators, the X37 offers outstanding detection sensitivity of contaminants, including glass, metal, calcified bone, high-density plastics and rubbers. Each contaminant can be detected in a range of packaging types such as metal can, glass and plastic containers, as well as doypacks, cartons, and composite cans/ tubes. Simultaneously, multiple product integrity checks can be performed, offering not just product safety but complete brand protection.



Model and Application Overview

X-ray Inspection System	Generator			Detector*
	20W	100W	420W	0.8mm
X3710	•			•
X3720		•	•	•
X3725		•	•	•
X3730		•	•	•
X3735		•	•	•
X3750			•	•

Packaging Type	Recommended System					
	X3710	X3720	X3725	X3730	X3735	X3750
Composite Cans/Cartons/Tubes	•	•	•			
Plastic Containers	•	•	•			
Doypacks	•	•	•			
Metal Containers		•	•	•	•	
Glass Containers				•	•	•
Ceramic Containers				•	•	

* 0.4mm detector available upon request

Please note that the above table is for indication purposes only, please contact your local sales representative for more information.

X37 Features & Benefits

The Big Difference is in Every Detail

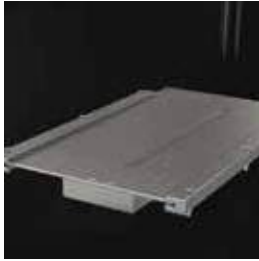

Multiple Detector Options
0.4mm/0.8mm diode size options are available to best fit the customers application and inspection requirements.

Low, Medium and High-Powered Generators

No active cooling required on machines where the 20W generator is applicable, reducing power consumption and maintenance costs.



Full-Length Guide Rails
Adjustable and product specific guide rails offer quick and easy product set-up and change-over.



Throughput Capabilities
Capable of inspecting up to 1,200 containers per minute depending on application.

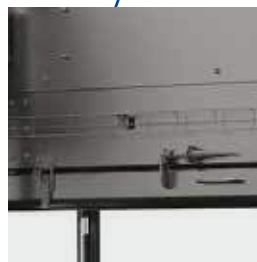
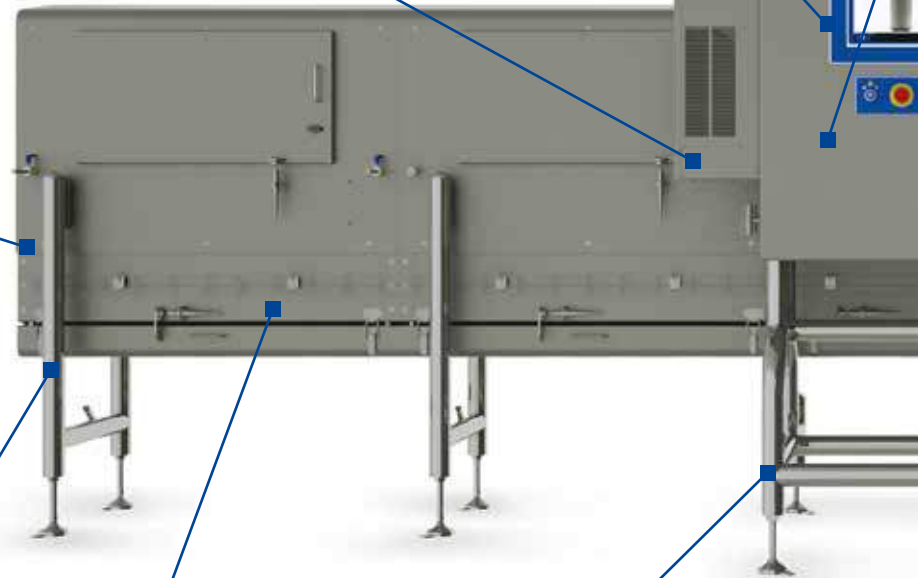

Outside Cable Trays
Avoiding bacteria traps and facilitating customers existing cables.

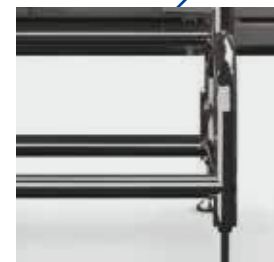

Robust Tubular Hygienic Frame Design
Hygienic design allows for water to roll off during cleaning.



Diverse Connectivity Options

Allows multiple methods to interact with the system and retrieve statistics/images including PackML.



Full Range of Inspection Tools

Simultaneously inspects products for contamination and product integrity to ensure brand protection.



Magnetic Safety Switches

Open access doors are easily and quickly identified, ensuring uptime.



Large Access Hatches

Improved access for cleaning and product set-up.



LED Lighting in Tunnel

Provides better visibility throughout the system.

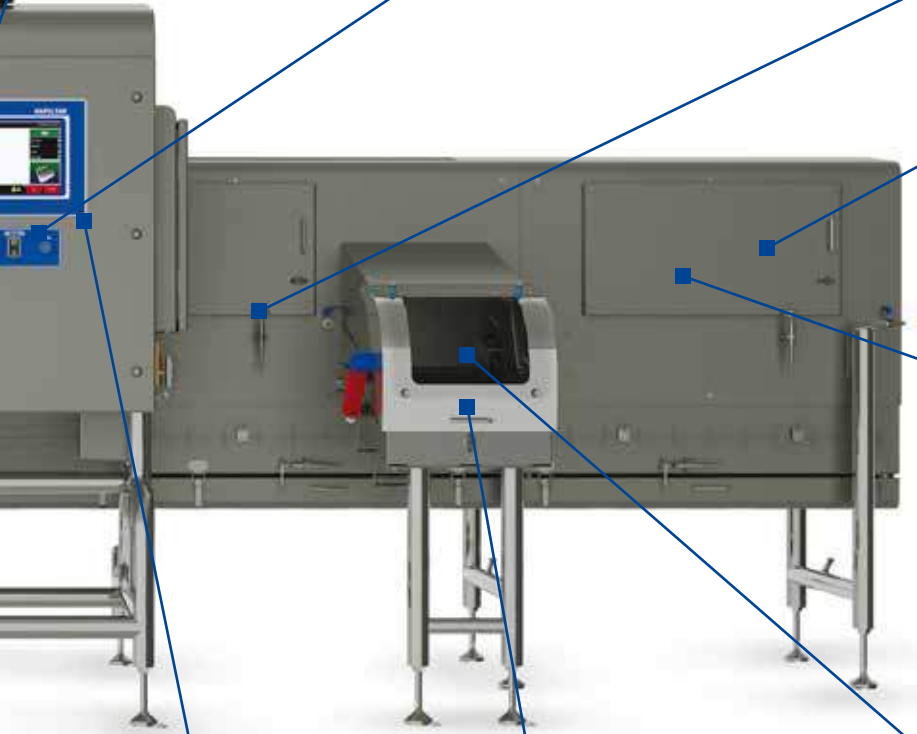

Robust LED Touch Screen

Suitable for high pressure wash-down (IP69 / Nema PW12).



Lockable Reject With Large-Vision Window

Available on the X3710/20/30, facilitates easier product set-up, demonstrating due diligence.

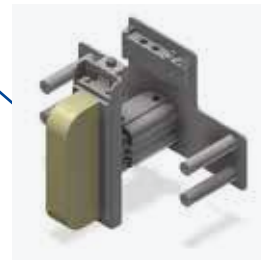

High-speed Reject Devices

Ensuring quick removal of faulty products at customer line speeds.

X37 Applications

The Big Difference is in Every Detail

The X37 Series of x-ray inspection systems ensures product safety and integrity for a wide variety of tall, rigid containers within the food and pharmaceutical industries.

METTLER TOLEDO Safeline X-ray has many years of experience inspecting a wide range of applications across the food and pharmaceutical industry, such as:

- Infant Foods
- Dairy
- Condiments
- Snacks
- Beverages
- Bakery and Confectionery
- Fruit and Vegetables
- Ready Meals
- Fish and Seafood
- Meat
- Pharmaceutical
- Pet Food

Types of Tall, Rigid Containers:

- Plastic Containers
- Metal Cans
- Glass Containers
- Composite Cans/Tubes/Cartons
- Ceramic Containers
- Doypacks

The X37 Series offers horizontal single-beam and split-beam solutions to cater for different inspection needs and to ensure reliable and consistent inspection for all types of tall, rigid container applications.

High throughput levels of up to 1,200 containers per minute can be achieved, depending on the application. The X37 Series can be installed in to existing production lines without slowing down the customer line speed.

The flexible design of the X37 Series can be fully configured to individual application requirements. With a choice of a 0.4mm or 0.8mm detector, optimum inspection results are achieved, even in the most demanding production environments.

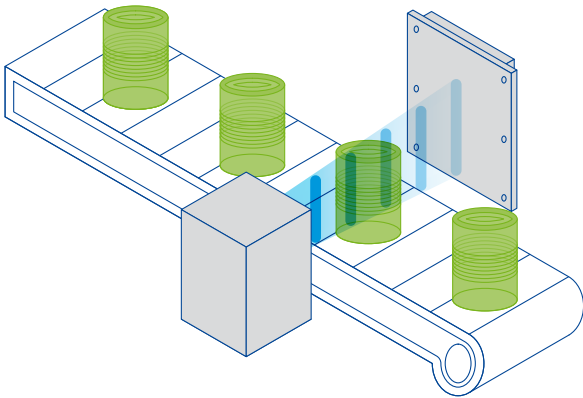

X3710, X3720 & X3725 horizontal single-beam systems

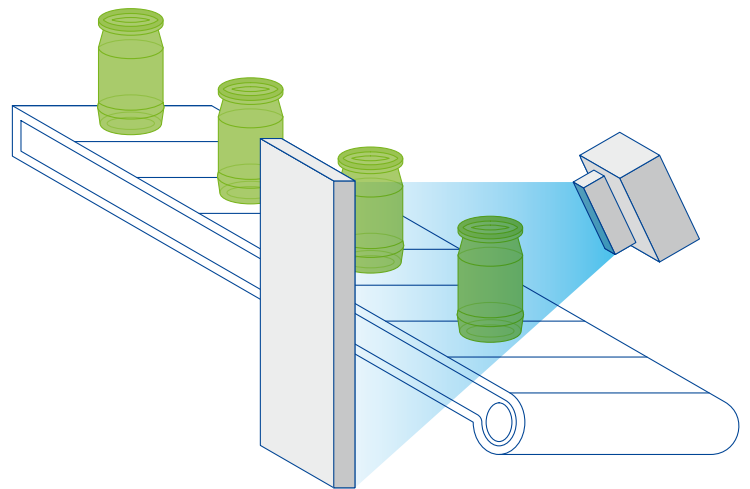

X3750 horizontal angled single-beam system

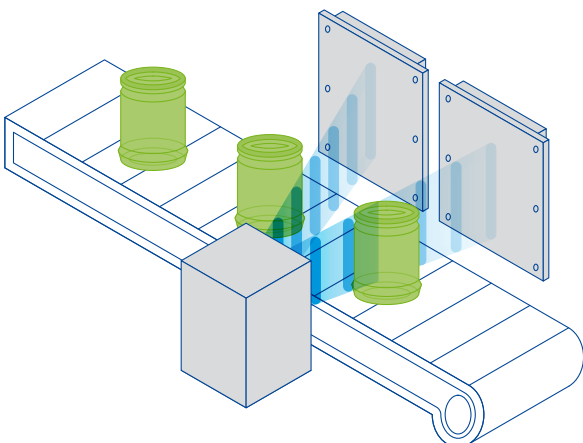

X3730 & X3735 horizontal split-beam system

X37 Inspection Capabilities

The Big Difference is in Every Detail

X37 Series Product Inspection Tools

The X37 Series of x-ray systems can detect contaminants while simultaneously performing product integrity checks such as:

- Inspecting fill levels and measuring head space
- Detecting missing closures
- Rejecting damaged packaging
- Detecting agglomerates such as flavor and powder lumps

Contaminant Detection

The X37 Series is capable of detecting a wide range of physical contaminants such as glass, metal, calcified bone, high-density plastics and rubber, ensuring product safety.

Inspect Fill Levels and Measure Head Space

The X37 Series is able to inspect fill level and measure head space of each container, minimizing product waste and ensuring product freshness.

Detect Missing Closures

The X37 Series can reliably inspect the presence of caps or lids on containers, ensuring the product is sterile, fresh and without any spillages.

Reject Damaged Packaging

Damaged products on a supermarket shelf can lower a consumer's perception of a brand. The X37 Series can detect damaged products such as dented cans and squashed cartons.

Detect Agglomerates

The detection of agglomerates such as flavor and powder lumps ensures consistent product presentation and customer experience.



Reject Systems

There are a number of different types of high-speed reject systems available to match manufacturers' production needs, while guaranteeing easy and effective removal from the line. The correct choice depends on a number of factors such as environmental conditions, belt speed, pack weight and pack size. The X37 Series has a choice of reject systems with vision windows, lockable bins or driven reject tables.

The high speed reject systems on Safeline x-ray machines do not slow down the customer line speeds and are capable of rejecting up to 1,200 products per minute, depending on application.

The lockable bin/reject area ensures due diligence, as only authorized personnel can access the rejected products.

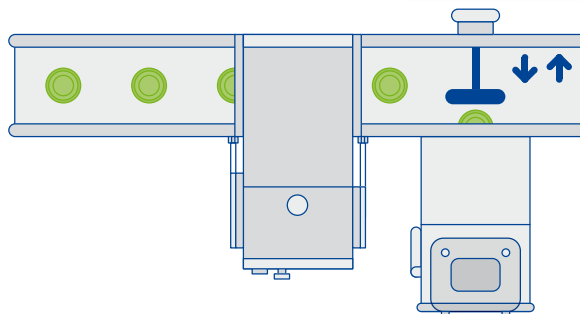

An x-ray system with a **side pusher reject system** is typically used for the rejection of medium and heavy-weight products commonly used on canning and glass-in-glass inspection lines.

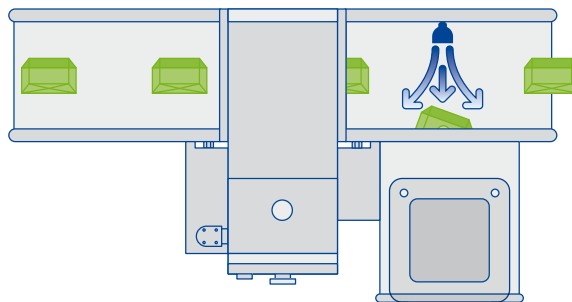

An x-ray system with an **air-blast reject system** works very well for small and medium packs including doypacks, plastic containers and composite cans and tubes.



The X37 Series is Built with Local and Global Standards in Mind

The seriousness with which the market views product safety issues is underlined by the wide range of national and international legislative and regulatory standards, as well as standards set by retailers. By incorporating appropriate inspection equipment into a company-wide approach to product safety, manufacturers can protect their reputations and meet legal obligations.



The X37 Series x-ray systems give food and pharmaceutical processors the tools to comply with standards such as Global Food Safety Initiative (GFSI) recognized schemes such as the British Retail Consortium (BRC) and International Featured Standards (IFS) or regulations such as the Food Safety Modernization Act (FSMA).

METTLER TOLEDO Service

METTLER TOLEDO Service wants you to maximize the return on your x-ray inspection equipment through a comprehensive services program consisting of four critical elements:

- **Uptime** - Support & Repair
- **Performance** - Set-up, Maintenance & Preventative Maintenance
- **Compliance** - Quality Assurance & Certification
- **Expertise** - Training & Education

5 Year X-ray Generator Warranty

Avoid unexpected costs and production downtime by ensuring the most expensive component of a x-ray system, the x-ray generator, is covered.

www.mt.com/xray-warranty

www.mt.com/xray-x37

For more information

Mettler-Toledo Product Inspection

1571 Northpointe Parkway
Lutz, FL 33558
Tel: (800) 447-4439
Fax: (813) 881-0840
Email: pi.marketing@mt.com

Subject to technical changes
©08/2018 Mettler-Toledo Product Inspection
Printed in the USA