

## Vertical Ribbon Mixer

The NBE Vertical Ribbon Mixer is designed to quickly and thoroughly mix batches of powders and other dry solids. The unique design of the continuous helical mixing ribbon, bottom mounted drive package, and clean-sweep bottom blade guarantee a homogeneous mixed, contamination free, and completely discharged batch. The easily removable top cover and mixing ribbon assembly render this design the easiest cleaning ribbon mixer on the market. The compact footprint also saves valuable floor space over horizontal ribbon mixers.

## Features

- Carbon & Stainless Steel Construction
- Conical Shaped Spiral Mixing Paddle
- Bottom Drive Assembly
- Top Loading
- Bottom Discharge with Pneumatic Slide Gate
- Heavy Duty Fork Pockets

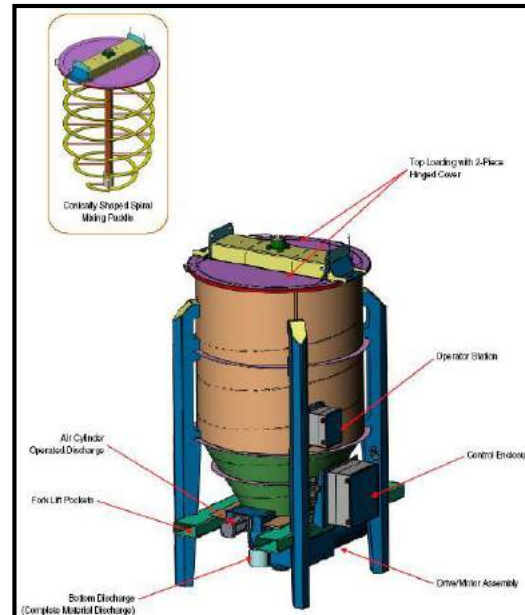

# Vertical Ribbon Mixer

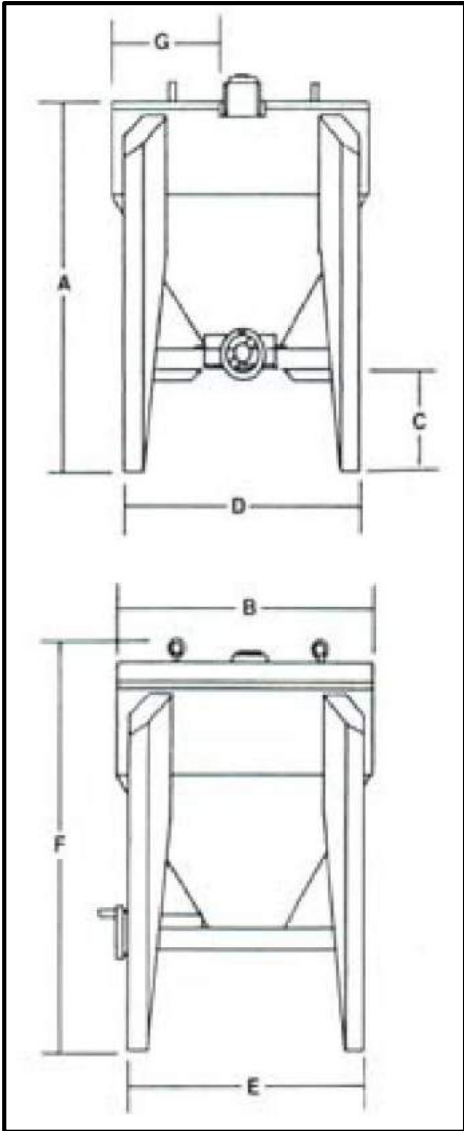

## Dimensional Specifications

Model No.	A	B	C	D	E	F	G
45-550	57"	52.5"	20"	44"	44"	65"	21"
45-750	67"	52.5"	20"	44"	44"	74"	21"
45-1000	76"	52.5"	20"	44"	44"	84"	21"
45-1500	95"	52.5"	20"	44"	44"	103"	21"

## Operational Specifications

Model No.	Batch Capacity ft <sup>3</sup>	Discharge Opening	Electrical
45-550	20	4" x 8"	7.5 HP / 3 Phase 230-460 VAC
45-750	30	4" x 8"	10 HP / 3 Phase 230-460 VAC
45-1000	40	4" x 8"	15 HP / 3 Phase 230-460 VAC
45-1500	60	4" x 8"	20HP / 3 Phase 230-460 VAC

# 45-550 Vertical Ribbon Mixer

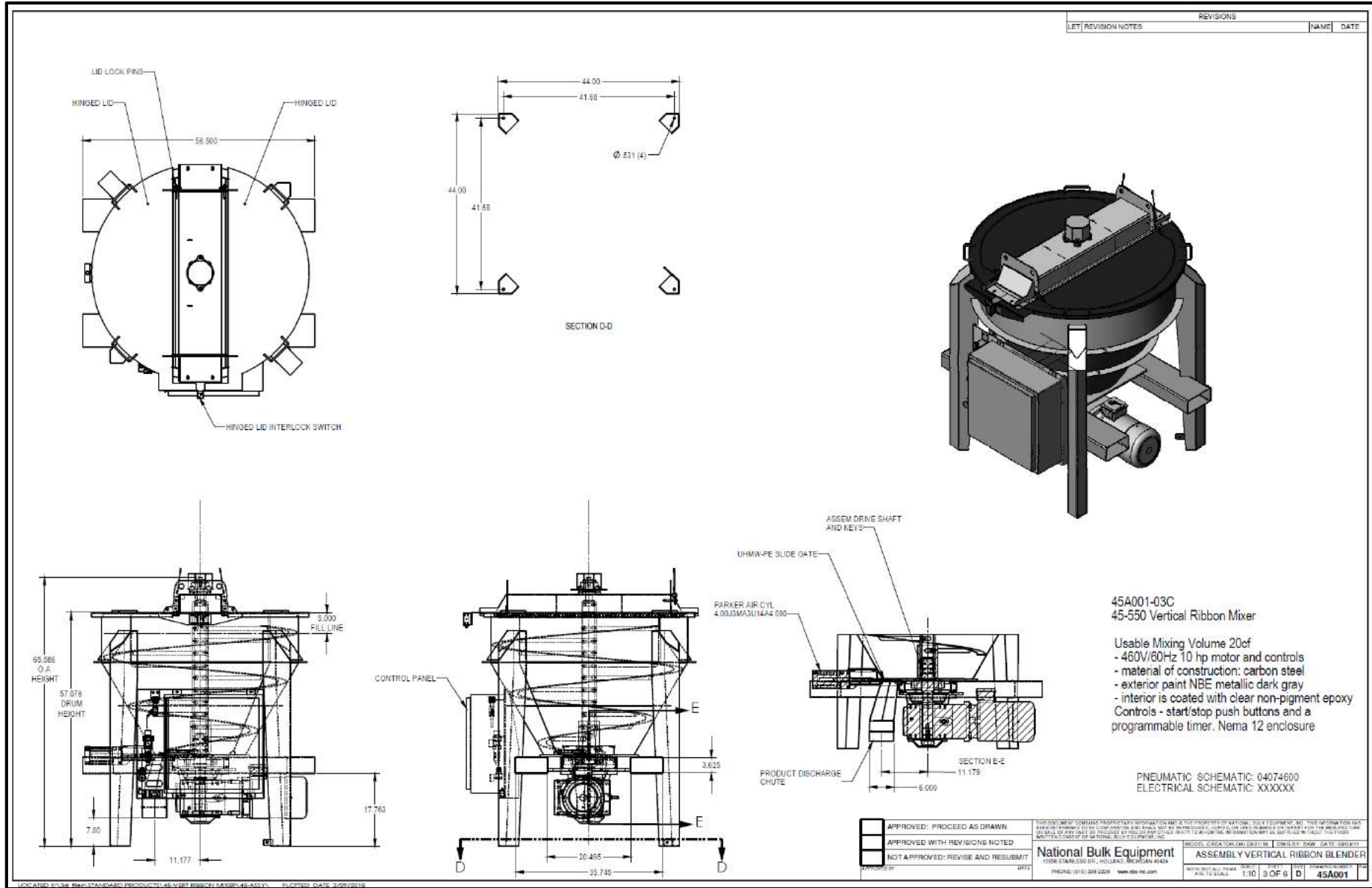

**NATIONAL BULK EQUIPMENT**  
AN NBE COMPANY

# 45-1000 Vertical Ribbon Mixer

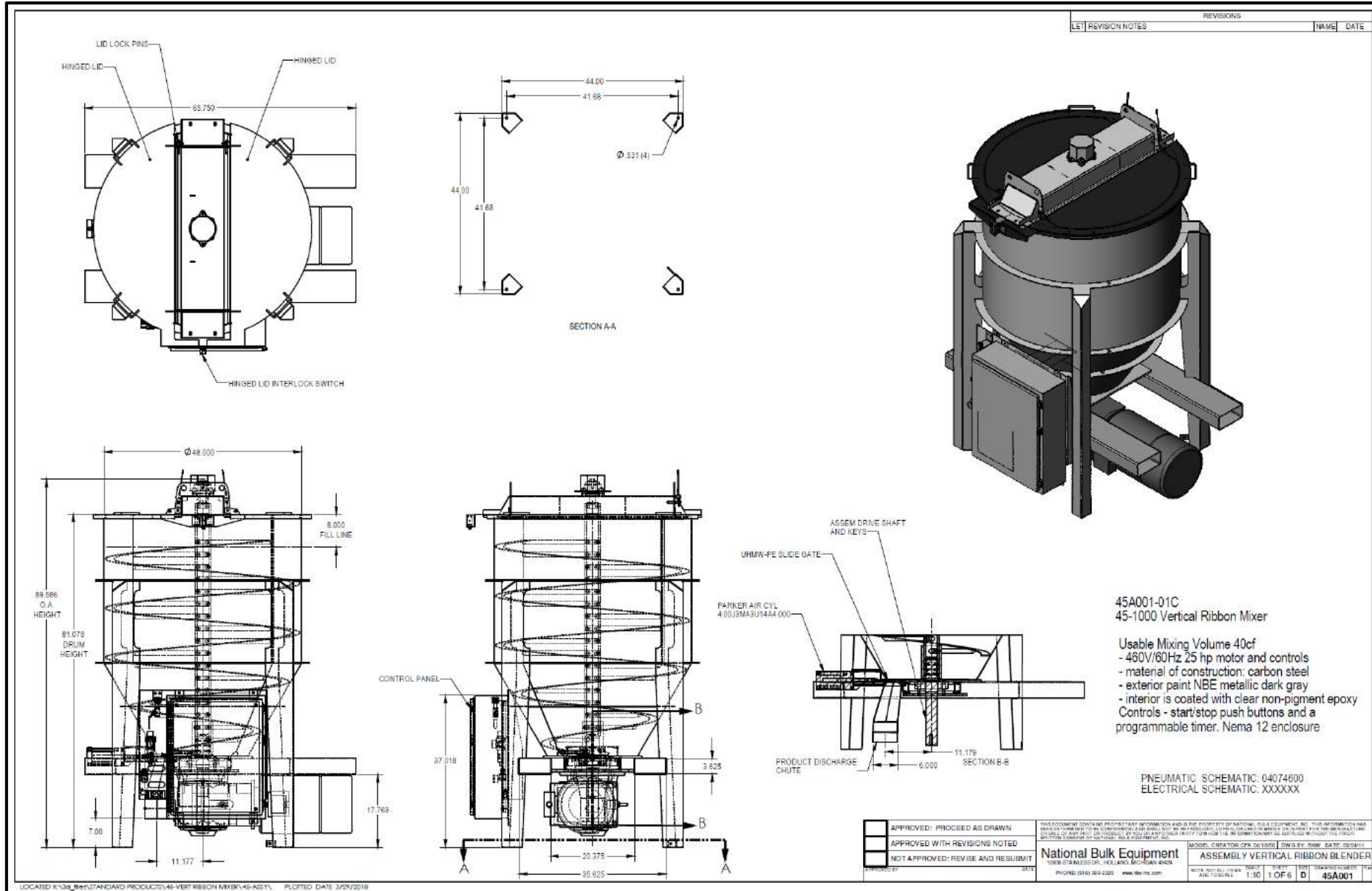

# 45-1500 Vertical Ribbon Mixer

