

QUADRO® COMIL® OVERDRIVEN SERIES

THE ORIGINAL
CONICAL SCREEN MILL

Fully scalable with
accurate and repeatable
results



QUADRO

QUADRO® COMIL® OVERDRIVEN SERIES

THE ORIGINAL CONICAL SCREEN MILL

The Comil® invented by Quadro in 1976, is the original conical mill for size reduction, deagglomeration, dispersion, separation and reclaim, as well as bulk density adjustments. Fully scalable from R&D to large-scale production volumes with accurate and repeatable results. The Comil® is built to last.



High-Efficiency Processing

The Quadro® Comil® Overdriven Series affords high capacities, narrow particle size distributions and less waste at a reduced cost of ownership. The Overdriven Comil® possesses an unrivaled track record for high-efficiency processing across an extensive range of industries.

Features & Benefits

- **Higher Capacities**
Steady-state milling owing to the Comil®'s choke / flood feeding capability
- **Low Heat**
Excellent for milling products with low melting points
- **Low Dust**
Provides savings in dust collection & explosion retention devices
- **Optimum Particle Size Distribution**
Ability to achieve desired particle granulometry
- **User-Friendly Design**
Simple screen changes, easy-clean, low maintenance & flexible feeding
- **Versatile**
Multiple screens & impellers available
- **Low Speed Design**
Applies gentle action to product
- **360° Positive Product Discharge**
Utilizes entire screen surface
- **Meets cGMP, CE and ATEX Requirements**



TECHNICAL DATA



Quadro® Comil® G-Series:

The Quadro® Comil® G-Series is available with 304SS, 1.06Ra (150 grit) contact surface finish, and 304SS bead blast non-contact surface finish suitable for food and industrial applications.



	197	194 / G94	196 / G96	198 / G98
Scale-Up Factor	1	5	10	20
Wet 375Q (9.5 mm) kg / hr (lbs / hr)	220 (480)	1100 (2400)	2200 (4800)	N/A
Dry 094R (2.4 mm) kg / hr (lbs / hr)	360 (794)	1750 (3858)	3500 (7716)	7000 (15,432)
Dry 040G (1.0 mm) kg / hr (lbs / hr)	80 (176)	400 (882)	800 (1764)	1600 (3527)
Motor HP (kW)	2 (1.5)	5 (4)	10 (7.5)	20 (15)
Inlet mm (in)	76 (3)	152 (6)	203 (8)	560 x 280 (22 x 11)
Outlet Diameter mm (in)	152 (6)	254 (10)	356 (14)	660 (26)
Dimensions L x W x H mm (in)	864 x 648 x 1204	1054 x 699 x 1302	1270 x 699 x 1459	1880 x 889 x 1295
*Legs Are Height Adjustable	(34 x 25.5 x 47.5)	(41.5 x 27.5 x 51.25)	(50 x 27.5 x 57.5)	(74 x 35 x 51)

NOTE: Capacities are product / equipment set-up dependent.
For specifications of Model 199 - approximately 15 times higher capacity than Model 198, please contact Quadro.

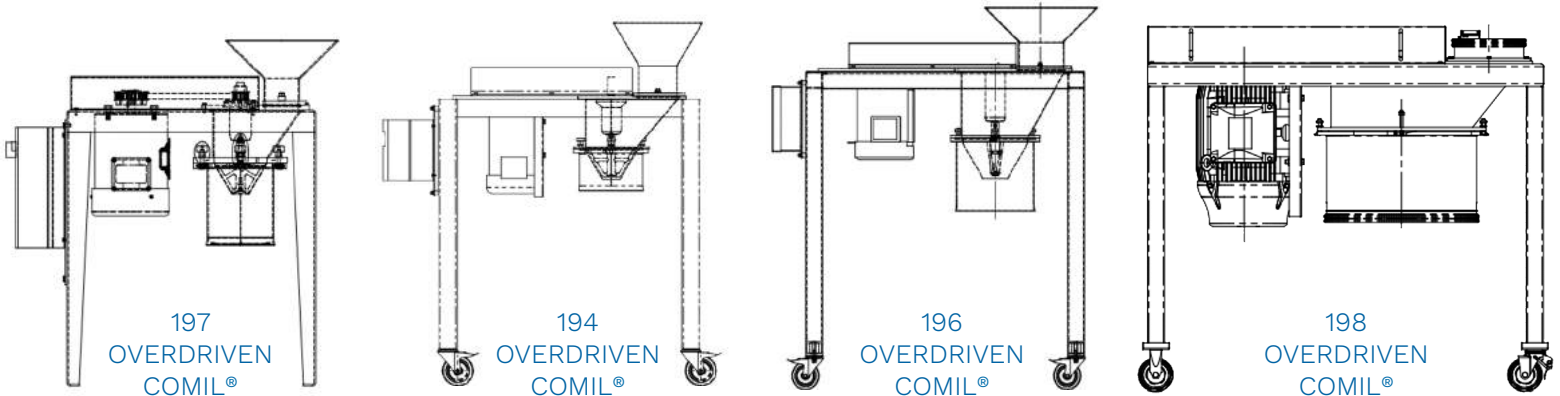

197
OVERDRIVEN
COMIL®

194
OVERDRIVEN
COMIL®

196
OVERDRIVEN
COMIL®

198
OVERDRIVEN
COMIL®

NOTE: 197 lab-scale model shown. Also available in pilot-scale.

INNOVATIVE PRODUCTS BACKED BY WORLD-LEADING EXPERTISE AND SUPPORT



Quadro Engineering Corp. continues to be the trusted partner of the world's leading pharmaceutical, food, personal care, fine chemical and biotech processing companies.

For over four decades, Quadro has endeavored to improve and refine their conical milling technology. Find out what underscores our reputation for supplying high quality powder processing equipment solutions. Let us help fulfill your specific application requirements.

Discover and experience the Quadro difference!

● Headquarters

● IDEX MPT Centers of Excellence

Representation in over 80 countries worldwide

Quadro Engineering Corp.

Tel: +1.519.884.9660

Email: quadrosales@idexcorp.com

www.quadro-mpt.com

613 Colby Drive

Waterloo, ON, Canada

Overdriven 09/20



Material Processing Technologies

Fitzpatrick | Matcon | Microfluidics | Quadro | Steridose