

Lump Breaker Overview

To ensure the supply to downstream processes of properly sized and conveyable material, NBE lump breaker systems are designed to deagglomerate material without shredding, cutting, or changing the shape of the material.

Equipment Options

- Light and heavy duty configurations
- Clean-In-Place (CIP)
- Standard and custom sizes
- Screenless and screen configurations
- Application specific impact “claws”
- Single and multiple shaft designs
- Special infeed hoppers
- Hazardous Environments

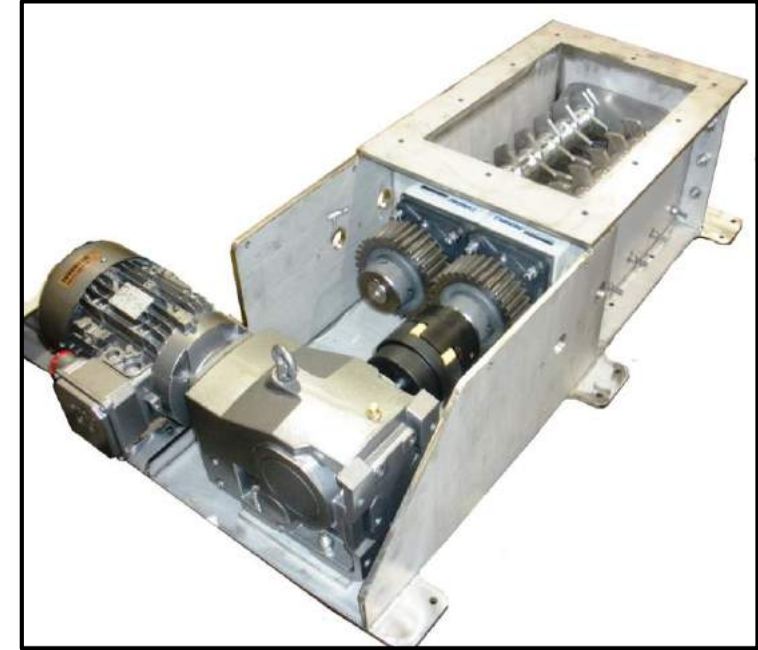

Heavy Duty Design Shown w/o guarding

Custom Lump Breaker Configurations

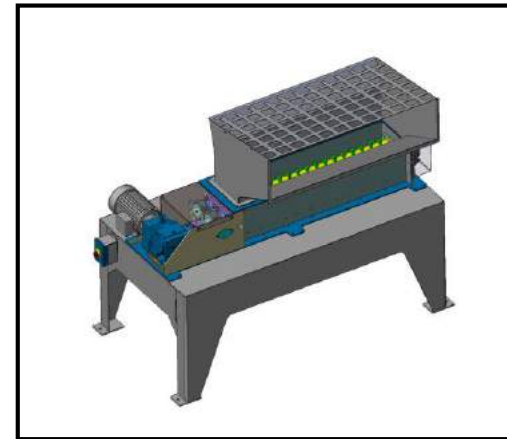
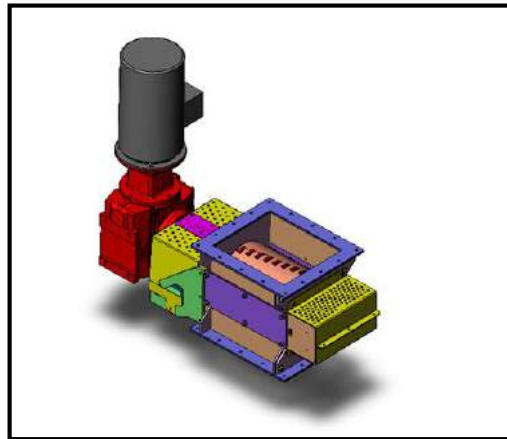
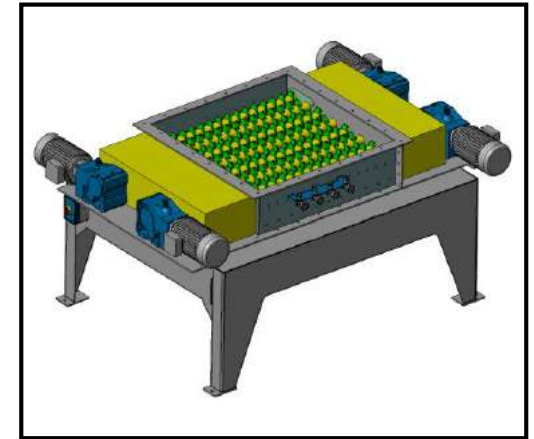
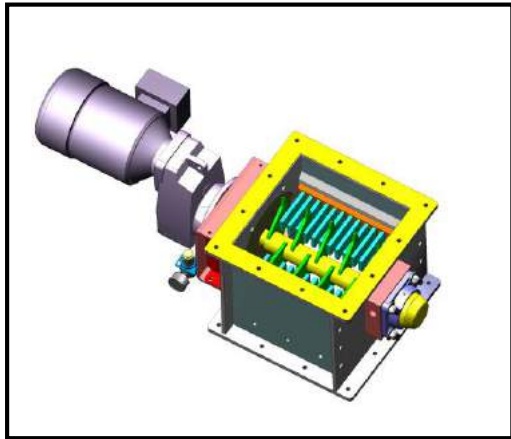

Standard 11" x 17" HD Lump Breaker

