



OPEN MOUTH BAG AUGER PACKER

MODEL APO DUAL

Magnum Systems Model APO Dual is designed with variable speed augers perfecting the art of “bulk and dribble” feeding. This technology allows the packer to feed material at three sequential speed settings which produces faster, more accurate measurements.

PACKAGE MATERIAL WHICH IS DIFFICULT TO FEED OR CONTROL WITH SPEED AND PRECISION

Features

- Product agitator for material conditioning
- Dual augers for bulk and dribble feeding
- Drop out bottom for ease of cleaning
- Enclosed discharge area and inflatable bag spout for dust control
- T4000 weigh controller with digital readout

Optional Features

- Stainless steel contacts with food grade finish
- De-aeration probes to stabilize fluidized products
- Bag settler
- Container platform and lift
- Removable screws and agitator
- T3000 weigh controller
- Automatic bag placer
- Downstream sealing, conveying and palletizing equipment

Materials Typically Handled

- Bakery mixes
- Flour
- Onion powder
- Seasoning blends
- Fish meal



DUAL AUGER PACKER

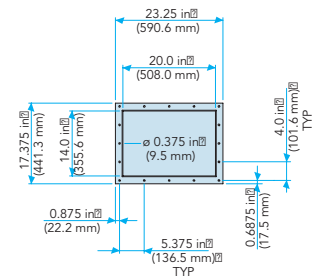
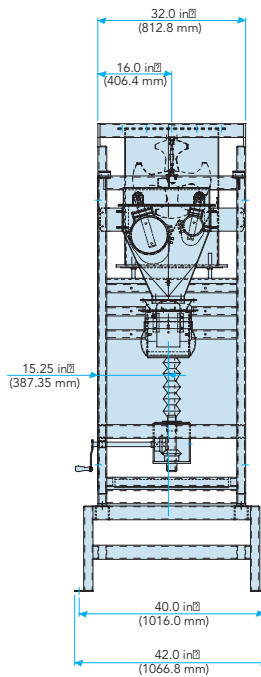
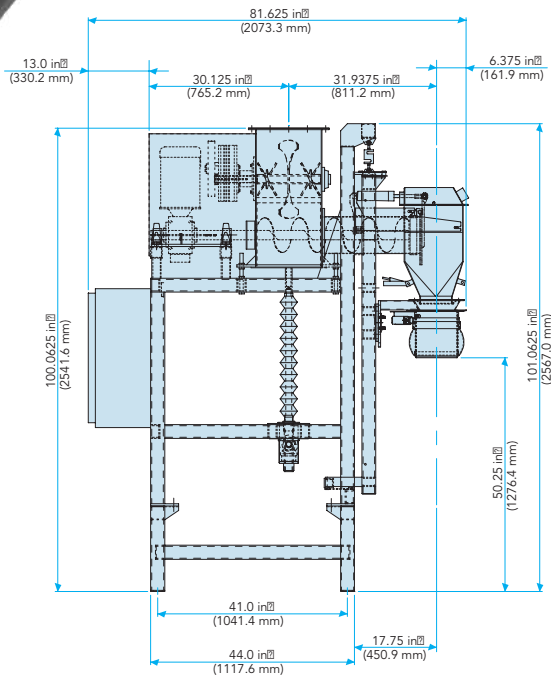

Diagram dimensions are for reference only*

SPECIFICATIONS

Speed	Up to 5 BPM
Accuracy	± 0.2%
Weight Range	20 to 125 lb (9 kg to 56 kg) <i>Weight range is dependent on product's bulk density. Free product testing recommended.*</i>
Configuration	Gross & Net-Weigh (Net-Weigh configuration requires an optional weigh bucket)
Construction	Carbon Steel Blasted & Painted
Scale	Analog, Digital
Electrical Requirements	230/460 Volt AC, 3 phase, 60 Hertz power for augers
Air Requirements	90 PSI (6 BAR) compressed air at 5 SCFM (<i>Compressed air must be clean and dry*</i>)
Inflatable Bag Clamp Capacity	60 lb (27 kg); capacities greater than 60 lbs require the optional bag support platform
Augers	304 Stainless Steel
Enclosures	NEMA12



AUGER SPOUT FLAP GATES

- Quick release pins for ease of maintenance & clean out
- Bulk and trim fill



INFLATABLE BAG SPOUT

- Dust Control
- Positive seal on bag



©2018 Magnum Systems, Inc. All rights reserved. Catalog number MS.1003.0218