

Rotary Valve ZXD

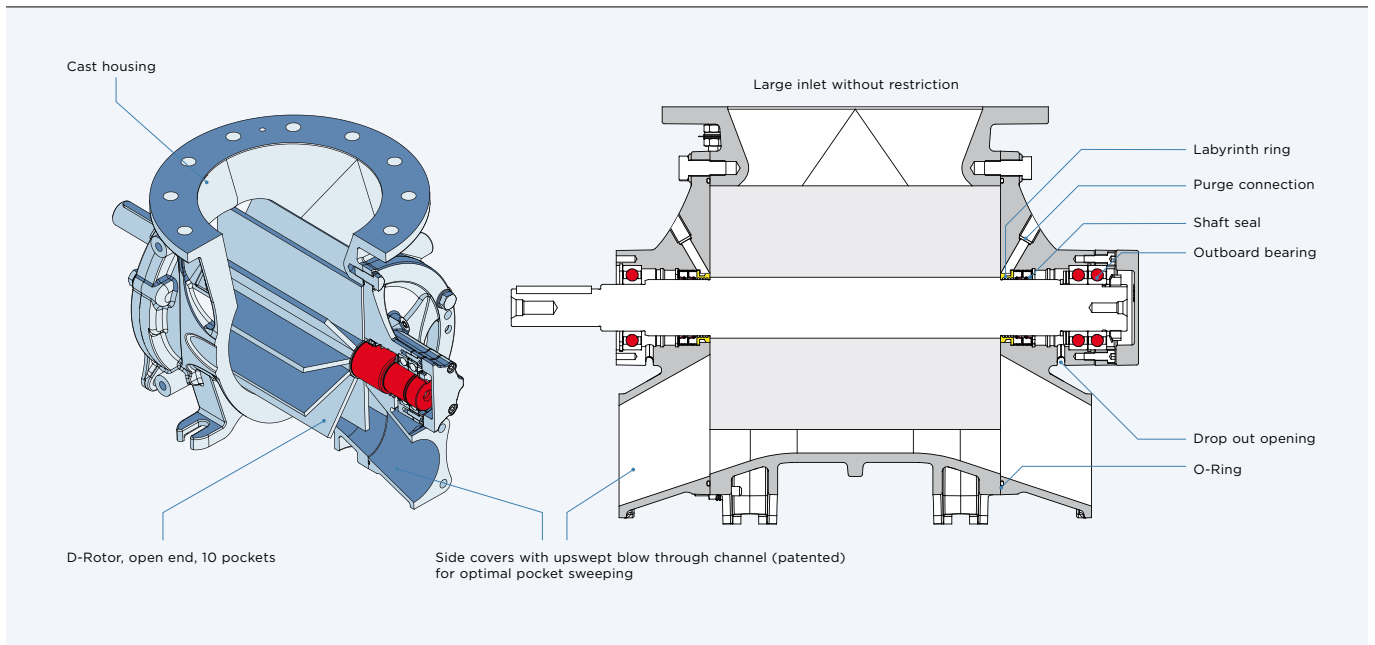

BLOW-THROUGH VALVE FOR POWDERS

- _ Large inlet for high capacities
- _ For feeding bulk materials into pneumatic conveying systems at up to 1.5 barg (21 psi)
- _ Operation possible without leakage gas venting



Performance diagram

- Powder with bulk density 1000 kg/m³ and 0.3 mm < d₅₀ < 0.6 mm, Δp = 0.8 barg
- Powder with bulk density 1000 kg/m³ and 0.075 mm < d₅₀ < 0.15 mm, Δp = 0.8 barg

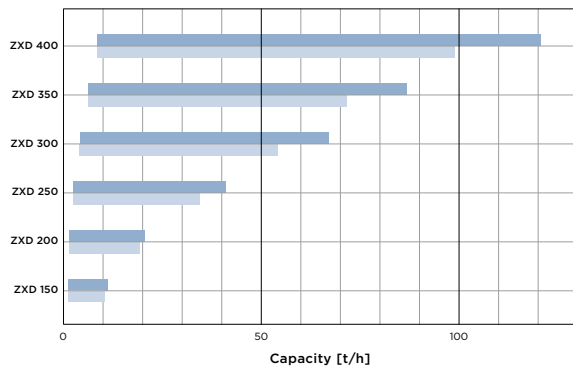

Leakage gas diagram

(New, standard clearance 60°C, max. speed)

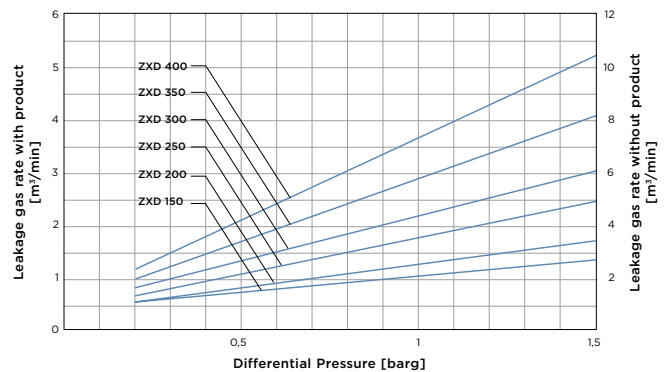

ROTARY VALVE FOR POWDERS | ZXD

PRESSURE RANGE 1.5 barg (21 psi) system and differential pressure
PRESSURE SURGE PROOF 10 barg (145 psi), due to heavy duty design
ATEX (OPTIONAL) Usable in Ex-Zones and as protection system (flameproof for dust ST2)
LARGE INLET Without restriction of the cross section for highest capacities
OUTBOARD BEARINGS Separated from product by purged seal arrangement and drop out opening
BLOW-THROUGH CHANNEL Optimal pocket sweeping at low pressure drop

OPTIONS AND ACCESSORIES

- _ Quick cleaning coupling with extraction device
- _ Chamfered blades
- _ Knife at the product inlet
- _ Scraper blades
- _ Wear protection
- _ Sanitary version

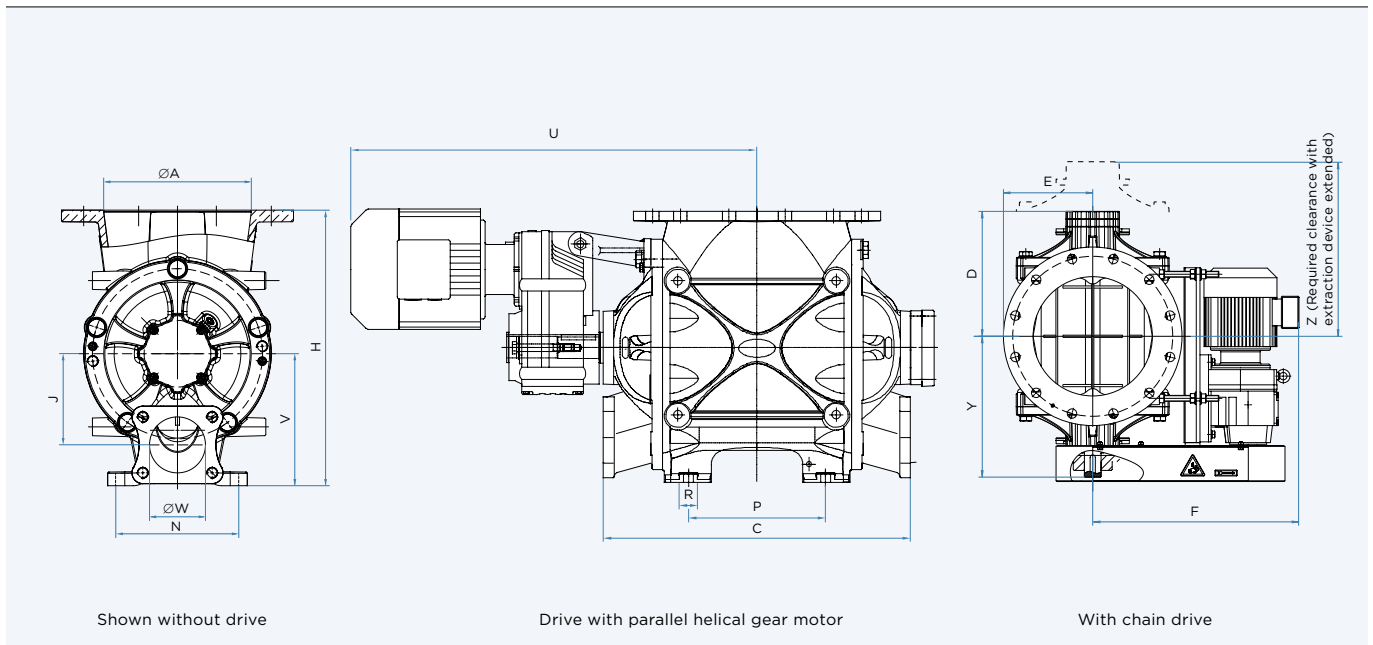

	Inlet*			Blow through channel			Mounting pattern			Other dimensions								Weight*** appr. kg	
	A (DIN)	A (ANSI)	Ø A	Ø W	J ₋₁ ¹	N	P	R	H ₋₁ ⁶	C ₋₂ ²	D	E	F**	Y	V ₋₁ ³	U**	Z**	AL	SS/GG
ZXD 150	ND 150	6"	168	69	128	112	130	14	350	366	229	142	390	271	181,0	665	703	30	54
ZXD 200	ND 200	8"	217	82	134	154	180	14	405	420	254	171	456	306	194,0	725	791	47	83
ZXD 250	ND 250	10"	272	107	158	168	225	18	445	504	302	206	499	367	230,7	790	1094	74	131
ZXD 300	ND 300	12"	322	132	193	220	275	18	560	580	337	241	578	380	287,5	912	1162	117	220
ZXD 350	ND 350	14"	360	160	205	240	330	23	620	660	371	267	591	437	313,0	962	1172	160	325
ZXD 400	ND 400	16"	410	184	212	310	372	23	715	600	401	299	712	467	375,0	992	1285	241	507

Dimensions in mm

* Drilled according to DIN PN 10 or ANSI 150 lbs

** Dimensions may vary depending on installed drive

*** Without drive