

## Bag Break Station with Glove Entry Design

When application specifications call for containment-level protection of operators from product, NBE engineered-to-application glove box material containment enclosures provide that protection throughout the material handling sequence. During packaged material loading, to opening, material input, and package disposal, the NBE material containment enclosure will maintain highly effective isolation of the material from the operator.



## Bag Break Station with Glove Entry Design



## Glove Box Integration with Bulk Bag Discharger

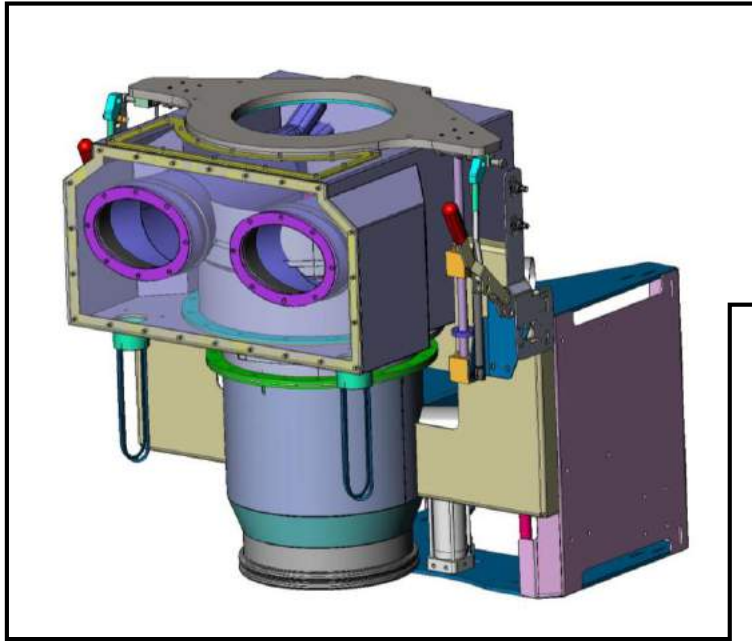

Glove Box with E3

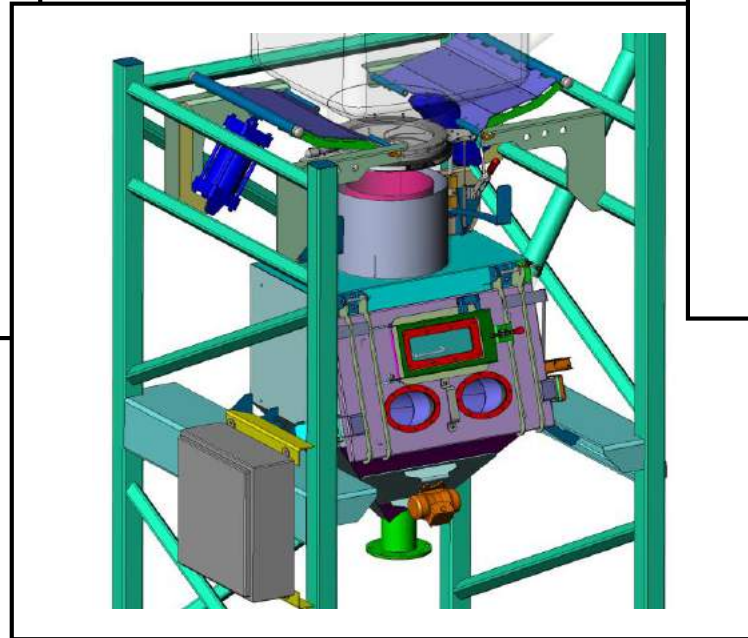

Glove Box with Bag Break Combo Hopper



Glove Box with E3 and Drum Filler